

Model	FVL1400	FVL1350
GCM (kg)	32,000	32,000
GVM (kg)	24,000	18,000
Max Power (kW)	221	221
Wheelbase (mm)	6470	6470
Suspension	Air	Air

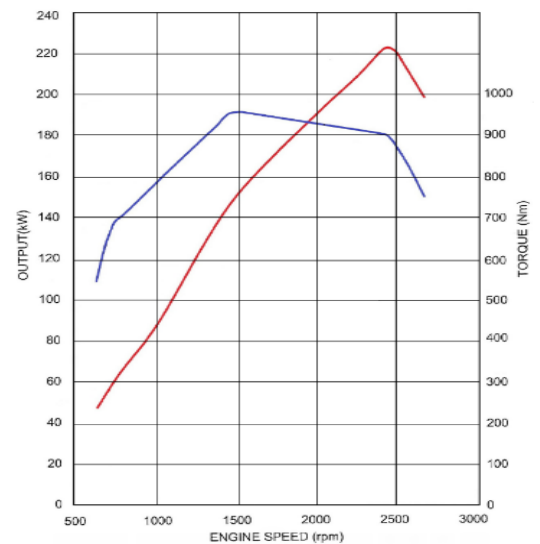

## ENGINE

<b>Engine Model:</b>	6HK1-TCS
<b>Type:</b>	6 cyl 24 valve, SOHC
<b>Displacement:</b>	7,790cc
<b>Compression Ratio:</b>	17.5:1
<b>Max Power (DIN Nett):</b>	221kW (300 HP) @2,400 RPM
<b>Max Torque (DIN Nett):</b>	980 Nm (723 lb.ft.) @1,450
<b>Emission Control System:</b>	Euro V with cooled EGR and Diesel Particulate Diffuser
<b>Fuel System:</b>	Electronically controlled direct injection, high pressure common rail 400 litre fuel tank with lockable fuel cap
<b>Air Intake System:</b>	Electronically controlled variable nozzle turbo charger with air-to-air Intercooler, vertical air intake behind cab



## PERFORMANCE

- **Maximum Towed Mass (braked):** 20,000kgs - **1<sup>st</sup> Gear Gradeability @GVM:** 44%/31% (1350)
- **Maximum Towed Mass (unbraked):** 2,500kgs - **Est Engine RPM @90km/h :** 2127

## TRANSMISSION

<b>Manual:</b>	ZF9 S 1110-TO - 9 spd manual, synchromesh on 1 <sup>st</sup> to 8 <sup>th</sup> with air assisted Double H shift pattern
<b>Clutch:</b>	Air assisted hydraulic control, 381mm single plate clutch
<b>PTO:</b>	Provision on right rear of transmission case, countershaft driven, counter-clockwise rotation viewed from front, ratio 0.77:1
<b>Ratios (:1)</b>	Crawler 9.48, 1 <sup>st</sup> 6.58, 2 <sup>nd</sup> 4.68, 3 <sup>rd</sup> 3.48, 4 <sup>th</sup> 2.62, 5 <sup>th</sup> 1.89, 6 <sup>th</sup> 1.35, 7 <sup>th</sup> 1.00, 8 <sup>th</sup> 0.75 Rev 8.97

## AXLES

<b>Front Axle:</b>	Meritor FG941
<b>Type:</b>	Elliot reverse I-beam
<b>Capacity:</b>	6,600kgs
<b>Rear Axle</b>	Meritor RS-23-161G and TR4670 tag axle
<b>Type:</b>	Full floating banjo drive axle & tag axle
<b>Final Drive:</b>	457mm diameter ring gear
<b>Ratio:</b>	6.142:1
<b>Capacity:</b>	18,100kgs

## CHASSIS

### Front Suspension

- Single stage alloy steel taper leaf spring

### Rear Suspension

- Hendrickson HAS 460 air bag suspension
- Outboard mounted double acting hydraulic Shock absorbers

### Steering

- Power assisted recirculating ball
- Gear Ratio 22.4:1
- Turns lock-to-lock 5.4

### Chassis Frame

- Cold riveted ladder frame with parallel side rails
- Rail dimensions (mm) 254 x 85 x 8
- HT540A weldable steel

### Brakes

- Meritor Q-Plus dual circuit, full air, S-cam drum brakes with auto-adjusting slack adjusters
- ABS
- Hill Start Aid
- Front drum 419mm x 127mm
- Rear drum 419mm x 178mm
- Spring park brake on rear wheels
- Air dryer
- Air controlled exhaust brake

### Wheels and Tyres

- Rims: 22.5 x 8.25 x 165mm 10-stud steel wheels
- Tyres: Steer: 295/80R22.5 tubeless tyres  
Drive: 11.00R22.5 tubeless tyres
- Frame mounted spare wheel with tyre

### Electrical

- 24 volt negative earth system
- 60 amp alternator
- Batteries - 2 x 115E41L 80Ah, 665CCA @ 18°C

## CAB AND INTERIOR

### CAB EXTERIOR

- All steel construction, high tensile steel on cab under-frame and side impact beam reinforcement
- Cab is fully compliant with ECE-R29 crash tests
- Manual cab tilt to 45° with torsion bar assistance
- Liquid filled cab mounts
- 90° opening internally reinforced doors
- Door mounted 19" heated power mirrors, flat glass on main and convex on spot mirrors
- Air dam steel front bumper with integral fog lamps
- Halogen multi-reflector headlamps with integral turn signals
- Additional door-mounted turn signal indicators with cornering lamps
- Roof-mounted outline marker lamps
- Combined brake/turn/reverse/marker lamps

### CAB INTERIOR

- Driver's seat - ISRI 6870 air suspended seat for occupant mass up to 150kg, pneumatic lumbar support, height, rake, auto weight adjustment
- Front passenger adjustable bucket seat and front centre seat with folding backrest, console in backrest

### CAB INTERIOR (continued)

- SRS including air bag on both outer seats
- Door and pillar entry assist grips both sides
- Lined interior, padded roof lining and vinyl floor covers
- Manual control integrated air conditioning
- Height/reach adjustable steering column, soft-feel Urethane steering wheel
- Central locking with keyless entry and engine immobiliser
- Door mounted storage pockets, LH and RH glove boxes, RH and LH overhead storage shelf
- Centre console with storage tray
- Fluorescent interior lamp
- Multi Media radio/CD/DVD/MP3/WMA Player with 6.2" Touch Screen, Bluetooth, voice dialling, text to speech, SD and USB inputs, on-board recordable memory – optional external cameras with up to 4-way screen, GPS navigation and many other options
- 5 DIN sized compartments for extra communications and storage

### INSTRUMENTS AND CONTROLS

- Tachometer, engine coolant temperature, fuel and dual brake air pressure gauges
- Two-speed wipers with intermittent wipe
- Key operated engine start, stop, steering lock
- HSA slow/fast engagement control with on/off switch
- DPD manual regenerate switch,
- **LH combination stalk:** windscreen wipers and washers exhaust brake
- **RH combination stalk:** Indicators, light switch, headlamp dip switch
- **Warning lamps:** Check engine, oil pressure, ABS, SRS, alternator charge, service brake, park brake on, seat belt, low air pressure, low fuel level, water-in-fuel, cab lock
- **Indicator lamps** – HSA, warm up system, high beam, DPD status, exhaust brake, turn signals
- **Multi info display** shows service interval, instant and average fuel cons, DPD bar chart, hour meter, voltmeter, time/day/date, 40-120 adjustable speed warning

## WEIGHTS (kgs)

Model Code	MODEL	RATINGS *		LOADING LIMITS (at ground)*		CHASSIS CAB TARE MASS **		
		GVM	GCM ***	FRONT	REAR	FRONT	REAR	TOTAL
FV1016	FVL 1350	18,000	32,000	6000	15,000	3410	3220	6630
FV0316	FVL 1400	24,000	32,000	6000	15,000	3410	3220	6630

\* Vehicle ratings and front and rear mass limits are subject to regulatory requirements – Consult your dealer to select a specific vehicle to suit your requirements

\*\* Chassis cab as supplied from the factory including 10 litres of fuel

## DIMENSIONS (mm)

Model	WB	OAL	OAH *	FOH	ROH	EA	CE	RT	ORT	FW	RFA *	BOC	Kerb to Kerb (m)
FVL 1350 & FVL1400	6470	11150	2810	1440	3240	5770	9085	1840	2445	850	1015	75	22.6

\* Unladen condition, chassis cab only

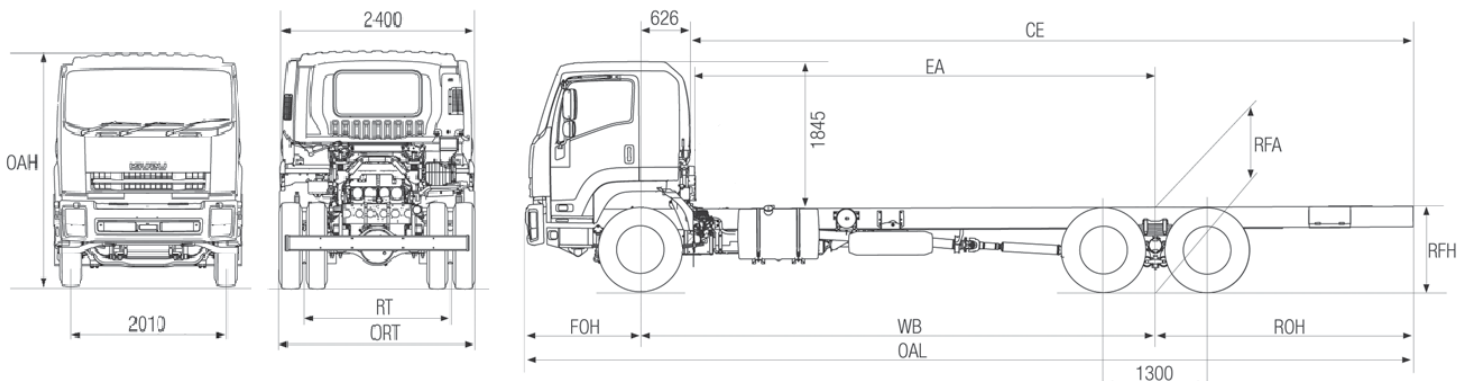

## WARRANTY

**Full vehicle warranty:** 36 months or 150,000 kilometres whichever occurs first

All warranty is subject to terms and conditions as detailed in the Owner's Manual Service and Warranty Supplement

A policy of continuous improvement means that these specifications are subject to change without notice. Contact your Isuzu dealer or visit our website at [Isuzu.co.nz](http://Isuzu.co.nz) to confirm specifications. Images of vehicles are representative only and may differ slightly from the actual vehicle