

Model	NPS450C	NPS425C
GCM (kg)	11,000	11,000
GVM (kg)	7,500	5,995
Max Power (kW)	114	114
Wheelbase (mm)	3395	3395
Licence**	Class 2	Class 1

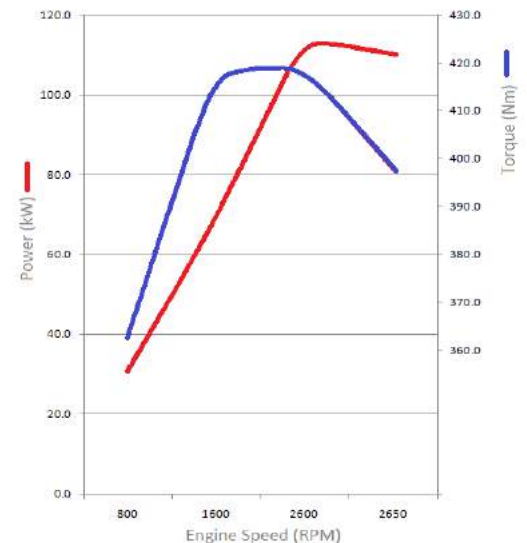

ENGINE

Engine Model:	4HK1-TCN
Type:	4 cyl 16 valve, SOHC
Displacement:	5,193 cc
Compression Ratio:	17.5:1
Max Power (DIN Nett):	114kW (155 HP) @2,600 RPM
Max Torque (DIN Nett):	419 Nm (309 lb.ft) @1,600 – 2600 RPM
Emission Control System:	Euro V Cooled EGR with Diesel Oxidation Catalyst, (DOC)
Fuel System:	Electronically controlled direct injection, high pressure common rail 140 litre fuel tank with lockable fuel cap Water-in-fuel sensor standard
Air Intake System:	Electronically controlled variable nozzle turbo charger with air-to-air intercooler, vertical air intake behind cab



PERFORMANCE

- **Maximum Towed Mass (braked):** 3,500kgs - **1st Gear Gradeability @GVM:** 425 58%/450 43%
- **Maximum Towed Mass (unbraked):** 2,000kgs - **Est Engine RPM @90km/h :** 2579

TRANSMISSION

Manual:	MYY5A 5 speed manual, synchromesh on 1 st to 5 th Auto adjusted 325mm single plate clutch, vacuum assist
Ratios (:1)	1 st 5.315, 2 nd 2.908 3 rd 1.558, 4 th 1.000, 5 th 0.721, Rev 5.068
Transfer box:	Part time 4WD High ratio 1.00:1, low ratio 1.842:1
PTO	Provision on LHS of transmission case, countershaft driven

AXLES

Front Axle:	Isuzu FD031
Type:	Full floating banjo type, Birfield outer joints Manual locking free wheel hubs
Capacity:	3,100kgs
Rear Axle:	Isuzu RO66
Type:	Full floating banjo type housing, limited slip differential
Capacity:	6,600kgs
Final Drive:	320mm diameter ring gear
Ratio (:1):	5.571

CHASSIS

Front Suspension

- Single stage alloy multi-leaf
- Double acting shock absorber
- Stabiliser bar

Steering

- Power assisted rack and pinion
- Turns lock-to-lock 3.7
- Gear Ratio 20.9:1

Chassis Frame

- Cold riveted ladder frame
- Rail dimensions (mm) 216 x70 x 6
- SAPH440 weldable steel
- Rear frame width (mm) 850

Rear Suspension

- MLS main with MLS helper
- MLS main 1300 x 70 x 11 – 4, 1300 x 70 x 10 - 1
- Constant 176N/mm
- MLS helper 850 x 70 x 9 – 7
- Combined constant 548 N/mm
- Double acting shock absorber

Brakes

- Anti-Lock Braking System (ABS), active in high range gear selection
- Front and rear drums with hydraulic dual circuit control, hydraulic assisted with load sensing proportioning valve
- Front drums 320 x 100mm
- Rear drum 320mm x 100mm
- 190mm diameter drum park brake on rear of transmission
- Exhaust brake

Wheels and Tyres

- 17.5 x 6.0 x 127mm 6-stud steel wheels
- 225/80R17.5-123/122L Bridgestone
- Silver painted wheel rims
- Frame mounted spare wheel with tyre

Electrical

- 24-volt electrical system
- 90-amp alternator
- Batteries - 2 x 80D26L 630CCA,

CAB AND INTERIOR

CAB EXTERIOR

- All steel construction, high tensile steel on cab under-frame and side impact beam reinforcement
- Cab is fully compliant with ECE-R29 crash tests
- Manual cab tilt to 45° with torsion bar assistance
- Liquid filled front and rear cab mounts
- Heavy duty non-slip cab entry steps
- 70° opening doors
- Cab mounted main mirrors on front of cab
- Halogen multi-reflector headlamps with integral front turn signals
- Additional door mounted turn signals
- Polycarbonate front bumper with steel frame
- Combined brake/turn/reverse/marker lamps
- Registration plate lamps
- Reverse alarm buzzer standard

CAB INTERIOR

- Contoured adjustable driver's bucket seat
- Passenger bench seat with capacity for two adults
- Centre seat has lap belt
- 3-point ELR seatbelts in outboard seat positions
- Driver's seat belt has pre-tensioner

CAB INTERIOR (continued)

- SRS including air bag for driver and passenger
- Door and pillar entry assist grips both sides
- Lined interior, padded roof lining and vinyl floor covers
- RH and LH overhead storage shelf
- Height/reach adjustable steering column, soft-feel urethane steering wheel
- Electric windows
- Central locking with keyless entry and immobiliser
- Twin cup holders, 24V cigarette lighter
- Integrated air conditioning with 4 speed fan
- Door mounted storage pockets, LH glove box
- Multi Media radio/CD/DVD/MP3/WMA Player with 6.2" Touch Screen, Bluetooth, voice dialling, text to speech, SD and USB inputs, on-board recordable memory – optional external cameras with up to 4-way screen, GPS navigation and many other options
- Fluorescent interior light
- 5 DIN sized compartments for extra communications

INSTRUMENTS and CONTROLS

- Speedometer with digital odometer and two trip meters, tachometer, engine coolant temperature, fuel level gauges
- Two-speed wipers with intermittent mode
- Key operated engine start/stop, steering lock
- High/low range and 4WD engagement switches
- **LH combination stalk:** Windscreen wipers, washers and exhaust brake
- **RH combination stalk:** Light switch, turn signals, headlamp dip switch
- **Warning lamps:** Check engine, oil pressure, SRS, ABS, alternator charge, service brakes, park brake on, seat belt unbuckled, low fuel.
- **Indicator lamps** – Warm up, system, high beam, exhaust brake on, turn signals, Low range on, 4WD engaged, turn signals

WEIGHTS (kgs)

Model Codes	MODELS	RATINGS *		LOADING LIMITS (at ground)*		CHASSIS CAB TARE MASS **		
		GVM	GCM	FRONT	REAR	FRONT	REAR	TOTAL
NP1915	NPS425C	5995	11000	3100	6000	2125	1085	3210
NP2015	NPS450C	7500	11000	3100	6000	2125	1085	3210

* Vehicle ratings and front and rear mass limits are subject to regulatory requirements – Consult your dealer to select a specific vehicle to suit your requirements
 ** Chassis cab as supplied from the factory including 10 litres of fuel

DIMENSIONS (mm)

Models	WB	OAL	CH *	FOH	ROH	EA	CE	RT	ORT	FW	RFA *	Kerb to Kerb (m)
NPS425 and NPS450 Crew	3395	5985	2495	1080	1510	1801	3331	1650	2120	850	950	13.6

*Unladen height

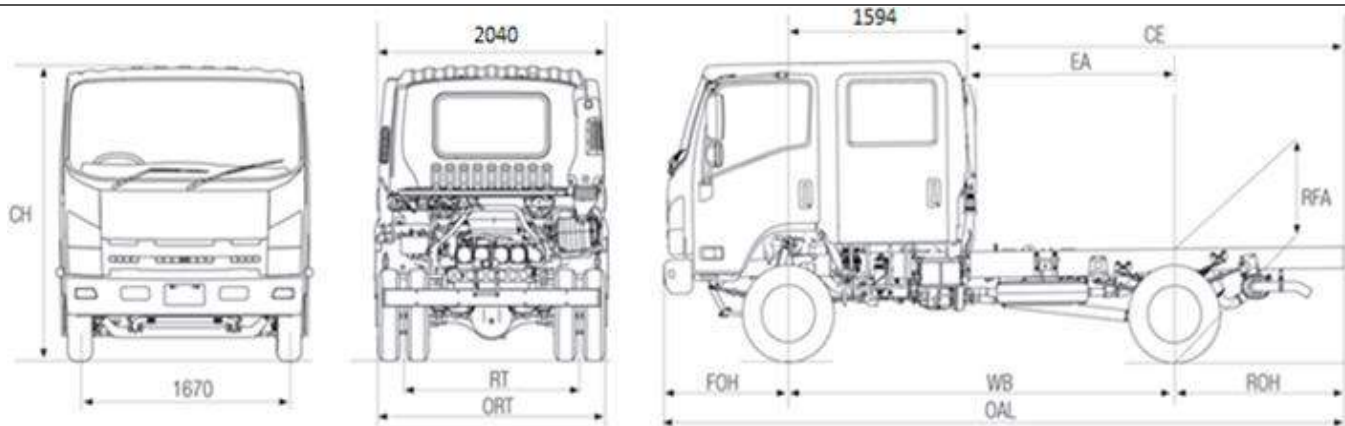

WARRANTY

Full vehicle warranty: 36 months or 100,000 kilometres whichever occurs first
 All warranty is subject to terms and conditions as detailed in the Owner's Manual Service and Warranty Supplement

A policy of continuous improvement means that these specifications are subject to change without notice. Contact your Isuzu dealer or visit our website at Isuzu.co.nz to confirm specifications. Images of vehicles are representative only and may differ slightly from the actual vehicle

** Always refer to NZTA to confirm & for Licensing changes