

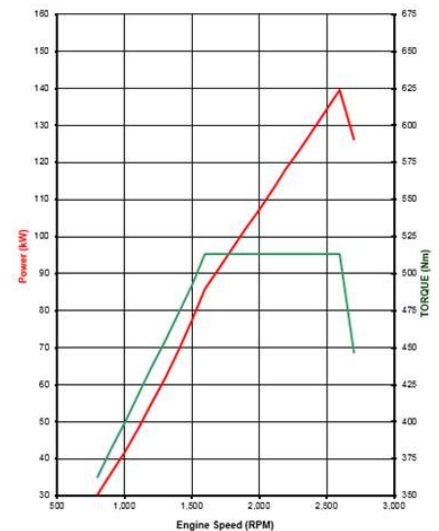

Model	NPR350C	NPR350C	NPR325C	NPR325C
GVM (kg)	6,500	6,500	5,995	5,995
GCM (kg)	10,000	10,000	9,495	9,495
Max Power (kW)	140	140	140	140
Wheelbase (mm)	4175	4175	4175	4175
License**	Class 2	Class 2	Class 1	Class 1

ENGINE

Engine Model:	ISUZU 4HK1-TCC
Type:	4 cyl 16 valve, SOHC
Displacement:	5,193 cc
Compression Ratio:	16.5:1
Max Power (DIN Nett):	140kW (188HP) @2,600 RPM
Max Torque (DIN Nett):	513 Nm (378 lb.ft) @1,600 – 2600 RPM
Emission Control System:	Euro V with cooled EGR and Diesel Oxidation Catalyst (DOC)
Fuel System:	Direct injection high pressure common rail system 140 litre fuel tank with lockable fuel cap Water-in-fuel sensor standard
Air Intake System:	Electronically controlled variable nozzle turbo charger with air-to-air intercooler, vertical air intake behind cab



PERFORMANCE

- 1st Gear Gradeability @GVM: model NPR325-64% & NPR350-58%, (AMT) NPR325-69% & NPR350-61%
 - Est Engine RPM @90km/h :2070, (AMT) 2170
- Speed Limit** - Customisable

TRANSMISSION

Manual:	ISUZU MZZ-6F 6 spd manual, synchromesh on 1 st to 6 th Auto adjusted 325mm diameter single plate clutch, vacuum assisted.
Ratios (:1)	1st 6.369, 2nd 3.767 3rd 1.966, 4th 1.355, 5th 1.000, 6th 0.782, Rev 6.369
AMT (optional)	ISUZU 6-Speed Automated Manual (AMT) full automatic and sequential manual shift modes.
PTO:	Provision on LHS of transmission case, countershaft driven & with wiring harness provided

AXLES

Front Axle:	Isuzu F031
Type:	Elliot reverse I-beam
Capacity:	3,100kgs
Rear Axle:	Isuzu RO66
Type:	Full floating banjo type housing
Capacity:	6,600kgs
Final Drive:	320mm diameter ring gear
Ratio (:1):	3.909 & 4.1 for AMT Transmission

CHASSIS

Front Suspension

- Single stage alloy multi-leaf
- Double acting shock absorber
- Stabiliser bar

Rear Suspension

- Multi Leaf Main Spring, Multi-leaf helper spring
- Double acting shock absorbers with stabiliser bar

Steering

- Power assisted rack and pinion
- Turns lock-to-lock 5.4
- Gear Ratio 20.9:1
- Maximum angle: 43° (inside wheel) / 33° (outside wheel)

Chassis Frame

- Cold riveted ladder frame & side members, rivet-less top flange
- JSH440 weldable steel
- Rail dimensions (mm) 216 x70 x 6
- Frame width (mm) 850

Brakes

- Auto adjusting front & rear disc with hydraulic dual circuit control, vacuum assisted with Electronic Brake Distribution (EBD)
- ABS and ASR (traction control)
- Hill Start Aid (except AMT)
- Front disc diameter 293 x 40mm
- Rear disc diameter 293 x 40mm
- 203mm diameter drum park brake on rear of transmission

Wheels and Tyres

- 17.5 x 6.0 x 127mm 6-stud steel wheel rims
- 205/75R17.5 124/122M tubeless tyres
- Silver painted wheel rims
- Frame mounted spare wheel

Electrical

- 24 volt negative earth system
- 90-amp alternator
- Batteries - 2 x 80D26L 80Ah, 630CCA, connected in series.

CAB AND INTERIOR

CAB EXTERIOR

- All steel construction, high tensile steel on cab under-frame and side impact beam reinforcement
- Cab is fully compliant with ECE-R29 crash tests
- Rubber front and rear cab mounts
- Heavy duty non-slip cab entry steps
- 90° opening doors
- Cab mounted main mirrors on front of cab
- Halogen multi-reflector headlamps with integral front turn signals
- Additional door mounted turn signals
- Polycarbonate front bumper with steel frame
- Combined brake/turn/reverse/marker lamps
- Registration plate lamps
- Reverse alarm buzzer standard

CAB INTERIOR

- Engine access provided under removable driver seat base and tiltable front passenger seat.
- Contoured adjustable driver's bucket seat
- Passenger bench seat with capacity for two adults
- Rear bench seat with 4 seat capacity
- 3-point seatbelts in all outboard seating positions. Driver and outboard front passenger seatbelts fitted with pretensioner. Centre seat lap belts
- Air bag for both front outer seats

CAB INTERIOR (continued)

- Door and pillar entry assist grips both sides
- Crew cab: Full width rear grab rail
- Lined interior, padded roof lining & vinyl floor covers
- RH and LH overhead storage shelf
- Height/reach adjustable steering column, soft-feel urethane steering wheel with audio controls
- Electric windows
- Central locking with keyless entry and immobiliser
- Twin cup holders, 24V cigarette lighter
- Integrated air conditioning with 4 speed fan
- Door mounted storage pockets
- Interior light
- Spare DIN sized communications compartment
- Multi-Media 6.2inch touch screen LCD (16:9)**
- Android OS Automotive V5.1, Music Box
- Internet radio via Wifi
- SMS: Text to speech feature & Bluetooth 4.0
- Optional accessories:** (contact your Isuzu dealer for full details).
 - Telematics-system
 - Parking sensors, tyre-pressure monitoring, Sat-Nav, Up to 4-cameras, 4-way split screen,
 - Advanced Driver Assistance System. (ADAS).

INSTRUMENTS and CONTROLS

- Speedometer with digital odometer, tachometer, integrated dual trip meter, engine coolant temperature, fuel level gauge.
- Two-speed wipers with intermittent wipe mode
- Key operated engine start/stop, steering lock
- HSA slow/fast engagement control with on/off switch (except AMT), ASR on/off switch
- AMT:** slow/fast clutch engagement control, 1st gear selection, economy mode
- LH** combination stalk: Windscreen wipers, washers & exhaust brake
- RH** combination stalk: Indicators, light switch & headlamp dip switch, cruise control, **(AMT only)**
- Warning lamps:** Check engine, oil pressure, ABS, SRS, alternator charge, service brake, park brake on, seat belt unbuckled, AMT check
- Indicator lamps – HSA (**except AMT**), warm-up system, high beam, 1st gear start, turn signals
- AMT model:** Multi-information display. Shows service interval, instantaneous & average fuel consumption, hour meter, voltmeter, time/day/date & includes 40-120 km/h adjustable vehicle, speed warning.

WEIGHTS (kgs)

Model Codes	MODELS	RATINGS *		LOADING LIMITS (at ground)*		CHASSIS CAB TARE MASS **		
		GVM	GCM	FRONT	REAR	FRONT	REAR	TOTAL
NP0718	NPR325 Crew	5995	9495	3100	6000	1985	925	2910
NP0818	NPR325 Crew AMT	5995	9495	3100	6000	1985	925	2910
NP1118	NPR350 Crew	6500	10000	3100	6000	1985	925	2810
NP1218	NPR350 Crew AMT	6500	10000	3100	6000	1985	925	2910

* Vehicle ratings and front and rear mass limits are subject to regulatory requirements – Consult your dealer to select a specific vehicle to suit your requirements

** Chassis cab as supplied from the factory including 10 litres of fuel

DIMENSIONS (mm)

Models	WB	OAL	CH *	FOH	ROH	EA	CE	RT	ORT	FW	RFA *	BOC	Kerb to Kerb (m)
All	4175	7338	2265	1110	2053	2510	4654	1650	2115	850	800	91	15.3

* Unladen condition, chassis cab only

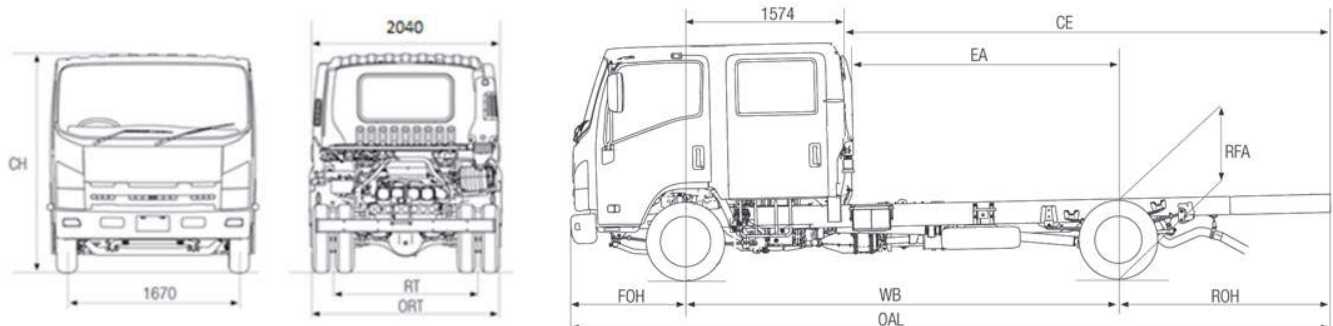

WARRANTY

Full vehicle warranty: 36 months or 100,000 kilometres whichever occurs first

All warranty is subject to terms and conditions as detailed in the Owner's Manual Service and Warranty Supplement

A policy of continuous improvement means that these specifications are subject to change without notice. Contact your Isuzu dealer or visit our website at Isuzu.co.nz to confirm specifications. Images of vehicles are representative only and may differ slightly from the actual vehicle

** Always refer to NZTA to confirm & for Licensing changes