

Model	FYH350M	FYH350A	FYH350S (man)
GCM (kg)	42,500	42,500	42,500
GVM (kg)	30,000	30,000	30,000
Max Power (kW)	257	257	257
Max Torque (Nm)	1422	1422	1422
Wheelbase (mm)	5770	5770	5080
Suspension	Steel	Steel	Steel



ENGINE

Engine Model:	6UZ1-TCC
Type:	6 cyl 24 valve, SOHC
Displacement:	9,839cc
Compression Ratio:	17.5:1
Max Power (DIN Nett):	257kW (350 HP(PS)) @2,000 RPM
Max Torque (DIN Nett):	1422Nm (1049 lb.ft) @1,400
Emission Control System:	Euro V with cooled EGR and Diesel Oxidation Catalyst (DOC), FYH350S – Vertical exhaust)
Fuel System:	Electronically controlled direct injection, high pressure common rail 200 litre alloy fuel tank with lockable fuel cap
Air Intake System:	Electronically controlled variable nozzle turbo charger with air-to-air intercooler, vertical air intake behind cab

PERFORMANCE

- Maximum Towed Mass (braked): 20,000kgs - 1st Gear Gradeability @GVM: M 26.5%/44% A
- Maximum Towed Mass (unbraked): 2,000kgs - Est Engine RPM @90km/h : M 1645/1690 A

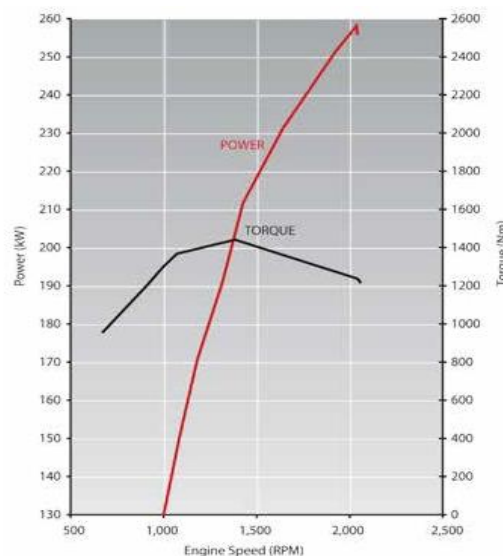

TRANSMISSION

Manual:	Eaton RTO 11909ALL 11 speed constant mesh
Clutch:	Air assisted hydraulic control, 432mm single plate clutch
PTO:	Flywheel LiveDrive, 1.1 ratio to engine speed, 440Nm output torque
Ratios (:1)	LL1 26.08, L 16.30, LL2 11.85, 1 st 7.41, 2 nd 5.23, 3 rd 3.79, 4 th 2.77, 5 th 1.95, 6 th 1.38, 7 th 1.00, 8 th 0.73 Rev LL 20.58, Rev L 13.03, Rev H 3.43
Auto:	Allison 4430 series 6 speed automatic transmission
PTO:	LH and top PTO openings on bellhousing
Ratios (:1)	1 st 4.70, 2 nd 2.21, 3 rd 1.53, 4 th 1.00, 5 th 0.76, 6 th 0.67 Reverse 5.55

AXLES

Front Axle:	Meritor FG941 on both steer axles
Type:	Elliot reverse I-beam
Capacity:	6,600kgs per axle
Rear Axle:	Meritor RT-40-145P
Type:	Full floating banjo type housing
Capacity:	18,100kgs
Final Drive:	393mm diameter ring gear, inter-axle lock and cross locks on both axles standard
Ratio:	5.285:1

CHASSIS

Front Suspension

- Single stage alloy steel taper leaf spring

Rear Suspension

- Isuzu 6-rod and trunion axle locating system
- Alloy steel parabolic tapered leaf springs

Steering

- Power assisted recirculating ball
- Gear ratio: 1st axle: 18.8:1, 2nd axle: 22.9:1
- Turns lock-to-lock 3.8

Chassis Frame

- Cold riveted ladder frame, HT540 weldable steel
- Rail dimensions (mm) 285 x 85 x 7
- Rail width 950mm at engine/transmission area, 850mm to rear of frame

Brakes

- Meritor Q-Plus dual circuit full air S-cam front & rear drum brakes auto-adjusting slack adjusters and LSPV
- ABS
- Front drum 419mm x 127mm
- Rear drum 419mm x 178mm
- Spring park brake on all rear wheels
- Air controlled exhaust brake
- Air dryer

Wheels and Tyres

- 22.5 x 8.25 10-stud ISO wheel rims
- Steer: 295/80 R22.5 152/148 L tubeless tyres
- Drive: 11 R22.5 148/145 L tubeless tyres
- White painted wheel rims
- Spare wheel rim supplied

Electrical

- 24 volt negative earth system
- 60 amp alternator
- Batteries - 2 x 115E41L 80Ah, 665CCA @ 18°C

CAB AND INTERIOR

CAB EXTERIOR

- All steel construction, high tensile steel on cab under-frame and side impact beam reinforcement
- Cab is fully compliant with ECE-R29 crash tests
- Manual cab tilt to 45° with torsion bar assistance
- Liquid filled cab mounts
- 90° opening internally reinforced doors
- Door mounted 19" heated power mirrors, flat glass on main and convex on spot mirrors
- Air dam steel front bumper with integral fog lamps
- Halogen multi-reflector headlamps with integral turn signals
- Additional door-mounted turn signal indicators with cornering lamps
- Roof-mounted outline marker lamps
- Combined brake/turn/reverse/marker lamps

CAB INTERIOR

- Driver's seat - ISRI 6860 air suspended seat for occupant mass up to 150kg, pneumatic lumbar support, height, rake, auto weight adjustment
- Front passenger adjustable bucket seat and front centre seat with folding backrest, console in backrest

CAB INTERIOR (continued)

- SRS including air bag on both outer seats
- Door and pillar entry assist grips both sides
- Lined interior, padded roof lining and vinyl floor covers
- Manual control integrated air conditioning
- Height/reach adjustable steering column, soft-feel Urethane steering wheel
- Central locking with keyless entry and engine immobiliser
- Door mounted storage pockets, LH and RH glove boxes, RH and LH overhead storage shelf
- Centre console with storage tray
- Fluorescent interior lamp
- Multi Media radio/CD/DVD/MP3/WMA Player with 6.2" Touch Screen, Bluetooth, voice dialling, text to speech, SD and USB inputs, on-board recordable memory – optional external cameras with up to 4-way screen, GPS navigation and many other options
- 5 DIN sized compartments for extra communications and storage

Instruments and Controls

- Speedometer with digital odometer and two trip meters
- Tachometer, engine coolant temperature, fuel and dual brake air pressure gauges
- Two-speed wipers with intermittent function, wet-wipe washer system
- Key operated engine start, stop, steering lock
- LH combination stalk: windscreen wipers/wash, exhaust brake
- RH combination stalk: Indicators, light switch, headlamp dip switch, cruise control
- Warning lamps: Check engine, oil pressure, ABS, SRS, alternator charge, service brake, park brake on, seat belt, low air pressure, low fuel level, cab lock
- Indicator lamps – Warm up system, high beam, turn signals, cruise control, exhaust brake
- Multi-function display Shows service interval, instant and average fuel consumption, hour meter, volt meter, time /day/date, 40 – 120 km adjustable vehicle speed warning

WEIGHTS (kgs)

Models	Model Code	RATINGS *		LOADING LIMITS (at ground)*		CHASSIS CAB TARE MASS **		
		GVM	GCM	FRONT	REAR	FRONT	REAR	TOTAL
FYH350M	FY0113	30,000	42,500	10800	15000	5815	2790	8605
FYH350A	FY0213	30,000	42,500	10800	15000	5710	2785	8495
FYH350S	FY0516	30,000	42,500	10800	15000	5790	2790	8580

* Vehicle ratings and front and rear mass limits are subject to regulatory requirements – Consult your dealer to select a specific vehicle to suit your requirements

** Chassis cab as supplied from the factory including 10 litres of fuel

DIMENSIONS (mm)

Models	WB	OAL	OAH *	OAW	FOH	ROH	EA	CE	RT	ORT	RFA *	Kerb to Kerb (m)
FYH350M	5770	9720	2998	1480	2470	5100	7570	1840	2445	1032	1044	21.5
FYH350A	5770	9720	2998	1480	2470	5100	7570	1840	2445	1032	1044	21.5
FYH350S manual	5080	9030	3453	1480	2470	4428	6880	1840	2445	1092	1105	16.88

* Unladen

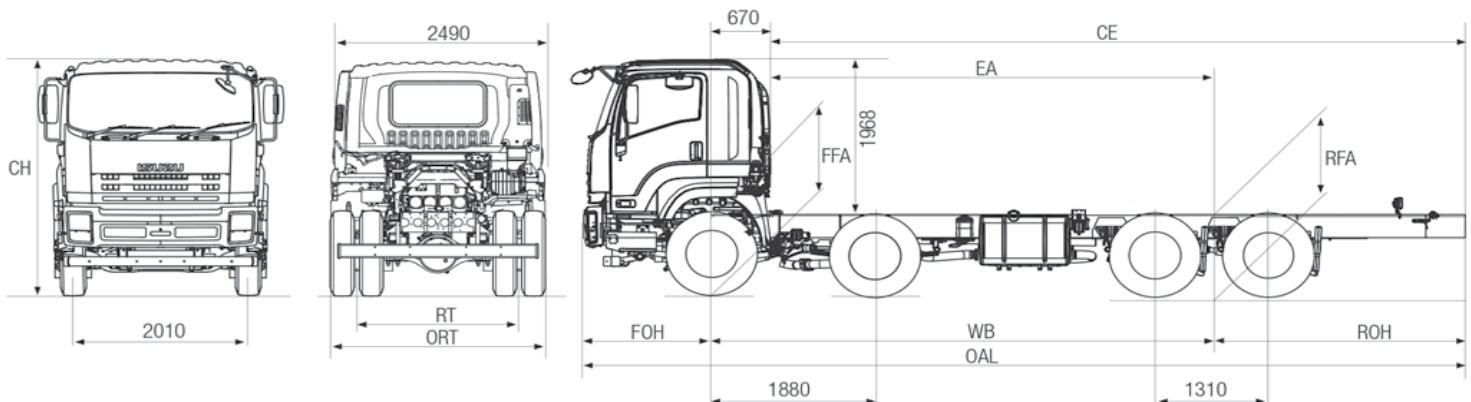

WARRANTY

Full vehicle warranty: 36 months or 200,000 kilometres whichever occurs first

All warranty is subject to terms and conditions as detailed in the Owner's Manual Service and Warranty Supplement

A policy of continuous improvement means that these specifications are subject to change without notice. Contact your Isuzu dealer or visit our website at Isuzu.co.nz to confirm specifications. Images of vehicles are representative only and may differ slightly from the actual vehicle