

Model	FVZ1400M	FVZ1350M	FVZ1400A	FVZ1350A
GCM (kg)	36,000	36,000	36,000	36,000
GVM (kg)	24,000	18,000	24,000	18,000
Max Power (kW)	221	221	221	221
Wheelbase (mm)	4410	4410	5300	5300
Suspension	Steel	Steel	Steel	Steel

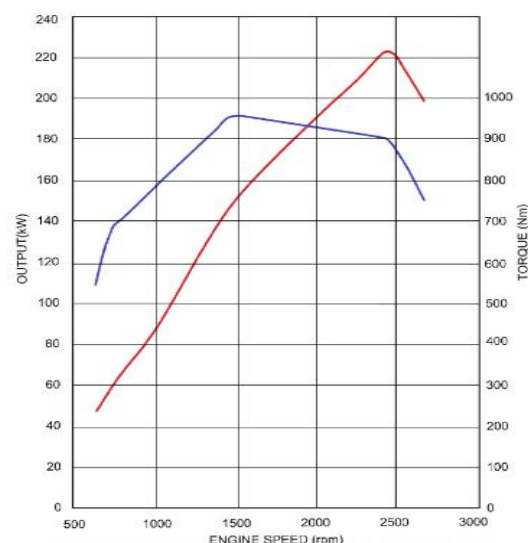

ENGINE

Engine Model:	6HK1-TCS
Type:	6 cyl 24 valve, SOHC
Displacement:	7,790cc
Compression Ratio:	17.5:1
Max Power (DIN Nett):	221kW (300 HP) @2,400 RPM
Max Torque (DIN Nett):	980 Nm (723 lb.ft.) @1,450
Emission Control System:	Euro V with cooled EGR and Diesel Particulate Diffuser
Fuel System:	Electronically controlled direct injection, high pressure common rail 400 litre fuel tank with lockable fuel cap
Air Intake System:	Electronically controlled variable nozzle turbo charger with air-to-air Intercooler, vertical air intake behind cab



PERFORMANCE

- Maximum Towed Mass (braked): 20,000kgs - 1st Gear Gradeability @ GVM: M 48%/23% A
- Maximum Towed Mass (unbraked): 2,000kgs - Est Engine RPM @90km/h : M 2120/ 2020 A

TRANSMISSION

Manual:	ZF-9S-1110-TO 9 spd manual, synchromesh on 1 st to 8 th with air assisted Double H shift pattern
Clutch:	Air assisted hydraulic control, 381mm single plate clutch
PTO:	Provision at rear of transmission case
Ratios (:1)	Crawler 9.48, 1 st 6.58, 2 nd 4.68, 3 rd 3.48, 4 th 2.62, 5 th 1.89, 6 th 1.35, 7 th 1.00, 8 th 0.75 Rev 8.97
Auto:	Allison MD3560P GEN 4 Wide ratio gearbox with TC419 converter
PTO:	PTO provision 4-o'clock & 8-o'clock, engine driven
Ratios (:1)	1 st 4.59, 2 nd 2.25, 3 rd 1.54, 4 th 1.00, 5 th 0.75, 6 th 0.65, Rev 5.00

AXLES

Front Axle:	Meritor FG941
Type:	Elliot reverse I-beam
Capacity:	6,600kgs
Rear Axle:	Meritor RT-40-145G
Type:	Full floating banjo drive axle
Final Drive:	457mm diameter ring gear
Ratio:	manual and auto 6.142:1
Capacity:	18,100 kgs

CHASSIS

Suspension

- Single stage alloy steel taper leaf spring
- Rear Suspension
- Multi leaf with 6 rod and trunion location

Steering

- Power assisted recirculating ball
- Gear Ratio 22.4:1
- Turns lock-to-lock 5.4

Chassis Frame

- Cold riveted ladder frame with parallel side rails
- Rail dimensions (mm) 254 x 85 x 8
- HT540A weldable steel

Brakes

- Meritor Q-Plus dual circuit, full air, S-cam drum brakes with auto-adjusting slack adjusters
- ABS
- Hill Start Aid (manual transmission only)
- Front drum 419mm x 127mm
- Rear drum 419mm x 178mm
- Spring park brake on rear wheels
- Air dryer
- Air controlled exhaust brake

Wheels and Tyres

- Rims: 22.5 x 8.25 x 165mm 10-stud steel wheels
- Tyres: FVZ Auto 275/70R22.5
FVZ Manual 11.00R22.5
Load rating 148/145 M tubeless tyres
- Frame mounted spare wheel with tyre

Electrical

- 24 volt negative earth system
- 60 amp alternator
- Batteries - 2 x 115E41L 80Ah, 665CCA @ 18°C

CAB AND INTERIOR

CAB EXTERIOR

- All steel construction, high tensile steel on cab under-frame and side impact beam reinforcement
- Cab is fully compliant with ECE-R29 crash tests
- Manual cab tilt to 45° with torsion bar assistance
- Liquid filled cab mounts
- 90° opening internally reinforced doors
- Door mounted 19" heated power mirrors, flat glass on main and convex on spot mirrors
- Air dam steel front bumper with integral fog lamps
- Halogen multi-reflector headlamps with integral turn signals
- Additional door-mounted turn signal indicators with cornering lamps
- Roof-mounted outline marker lamps
- Combined brake/turn/reverse/marker lamps

CAB INTERIOR

- Driver's seat - ISRI 6870 air suspended seat for occupant mass up to 150kg, pneumatic lumbar support, height, rake, auto weight adjustment
- Front passenger adjustable bucket seat and front centre seat with folding backrest, console in backrest

CAB INTERIOR (continued)

- SRS including air bag on both outer seats
- Door and pillar entry assist grips both sides
- Lined interior, padded roof lining and vinyl floor covers
- Manual control integrated air conditioning
- Height/reach adjustable steering column, soft-feel Urethane steering wheel
- Central locking with keyless entry and engine immobiliser
- Door mounted storage pockets, LH and RH glove boxes, RH and LH overhead storage shelf
- Centre console with storage tray
- Fluorescent interior lamp
- Multi Media radio/CD/DVD/MP3/WMA Player with 6.2" Touch Screen, Bluetooth, voice dialling, text to speech, SD and USB inputs, on-board recordable memory – optional external cameras with up to 4-way screen, GPS navigation and many other options
- 5 DIN sized compartments for extra communications and storage

INSTRUMENTS AND CONTROLS

- Tachometer, engine coolant temperature, fuel and dual brake air pressure gauges
- Two-speed wipers with intermittent wipe
- Key operated engine start, stop, steering lock
- HSA slow/fast engagement control with on/off switch
- DPD manual regenerate switch,
- LH combination stalk: windscreen wipers and washers exhaust brake
- RH combination stalk: Indicators, light switch, headlamp dip switch
- Warning lamps: Check engine, oil pressure, ABS, SRS, alternator charge, service brake, park brake on, seat belt, low air pressure, low fuel level, water-in-fuel, cab lock
- Indicator lamps – HSA, warm up system, high beam, DPD status, exhaust brake, turn signals
- Multi info display shows service interval, instant and average fuel cons, DPD bar chart, hour meter, voltmeter, time/day/date, 40-120 adjustable speed warning

WEIGHTS (kgs)

Model Code	MODEL	RATINGS *		LOADING LIMITS (at ground)*		CHASSIS CAB TARE MASS **		
		GVM	GCM	FRONT	REAR	FRONT	REAR	TOTAL
FV0616	FVZ1400M	24,000	36,000	6000	15,000	3385	3450	6835
FV0716	FVZ1400A	24,000	36,000	6000	15,000	3420	3450	6870
FV1316	FVZ1350M	18,000	36,000	6000	15,000	3385	3450	6835
FV1416	FVZ1350A	18,000	36,000	6000	15,000	3420	3450	6870

* Vehicle ratings and front and rear mass limits are subject to regulatory requirements – Consult your dealer to select a specific vehicle to suit your requirements

** Chassis cab as supplied from the factory including 10 litres of fuel

DIMENSIONS (mm)

Model	WB	OAL	OAH *	FOH	ROH	EA	CE	RT	ORT	FW	RFH *	BOC	Kerb to Kerb (m)
FVZ1400M/1350M	4410	7655	2810	1440	1805	3784	5589	1840	2450	850	1062	75	15.3
FVZ1400A/1350A	5300	9180	2810	1440	2440	4674	7114	1840	2450	850	1015	75	18.5

* Unladen condition, chassis cab only

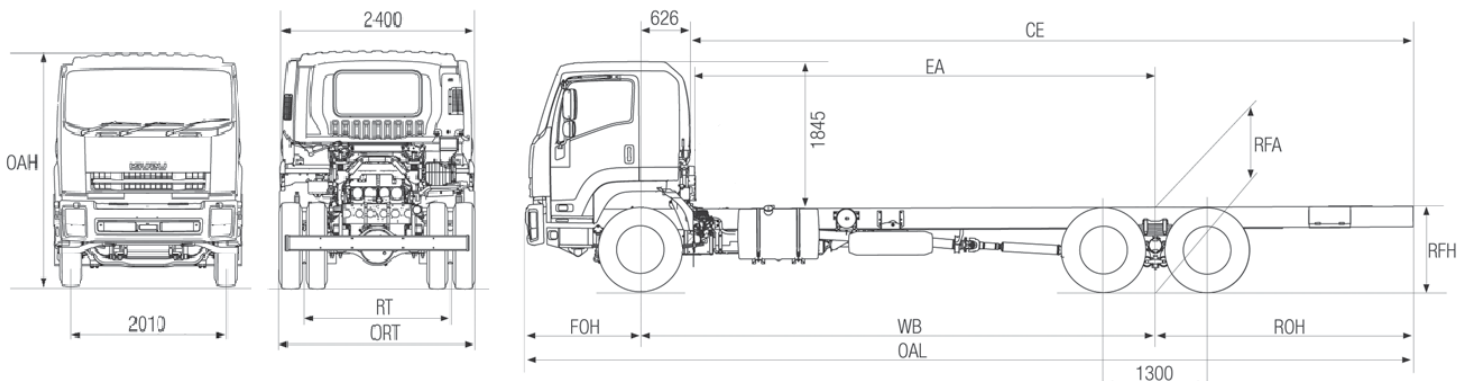

WARRANTY

Full vehicle warranty: 36 months or 200,000 kilometres whichever occurs first

All warranty is subject to terms and conditions as detailed in the Owner's Manual Service and Warranty Supplement

A policy of continuous improvement means that these specifications are subject to change without notice. Contact your Isuzu dealer or visit our website at Isuzu.co.nz to confirm specifications. Images of vehicles are representative only and may differ slightly from the actual vehicle