



AT A GLANCE

Configuration:	6x2
Gross Vehicle Mass:	18,000kgs / 24000kgs
Gross Combination Mass:	32,000kgs
Maximum Towed Mass (braked):	20,000kgs
Maximum Towed Mass (unbraked):	2,500kgs
1st Gear Gradeability @ GVM/GCM %:	44 / 23 31 / 23
Est. Engine RPM @ 90km/hr:	2127
Emission Standard:	Euro V
Speed Limiter:	100km/hr

ENGINE

Engine Model:	6HK1-TCS
Type:	6 cyl 24 valve, SOHC
Displacement:	7,790cc
Compression Ratio:	17.5:1
Max Power (DIN Nett):	221kW (300 HP) @2,400 RPM
Max Torque (DIN Nett):	980 Nm (723 lb.ft) @1,450
Emission Control System:	Euro V with cooled EGR and Diesel Particulate Diffuser
Lubrication:	Plate type oil cooler, spin on filter, 15.5 litre capacity
Cooling System:	Temperature controlled viscous fan hub System capacity approx 29.5 litres
Fuel System:	Electronically controlled direct injection, high pressure common rail 400 litre alloy fuel tank with lockable fuel cap Water-in-fuel sensor standard
Air Intake System:	Electronically controlled variable nozzle turbo charger with air-to-air intercooler, vertical air intake behind cab

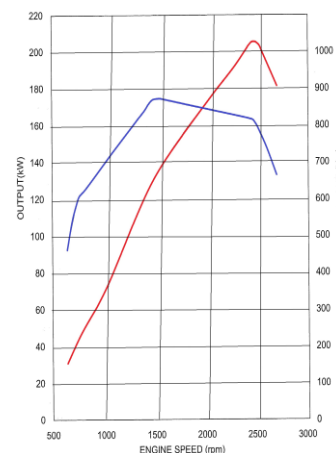

TRANSMISSION

Manual:	ZF9 S 1110-TO - 9 spd manual, synchromesh on 1 st to 8 th with air assisted Double H shift pattern
Clutch:	Air assisted hydraulic control, 381mm single plate clutch
PTO:	Provision on right rear of transmission case, countershaft driven, counter-clockwise rotation viewed from front, ratio 0.77:1
Ratios (:1)	Crawler 9.48, 1 st 6.58, 2 nd 4.68, 3 rd 3.48, 4 th 2.62, 5 th 1.89, 6 th 1.35, 7 th 1.00, 8 th 0.75 Rev 8.97
Oil capacity:	Approx 8.0 litres

AXLES

Front Axle:	Meritor FG941
Type:	Elliot reverse I-beam
Capacity:	6,600kgs
Rear Axle:	Meritor RS-23-161G and TR4670 tag axle
Type:	Full floating banjo drive axle & tag axle
Final Drive:	457mm diameter ring gear
Ratio:	6.140:1
Capacity:	20,000kgs
Oil capacity:	Approx 15.0 litres

CHASSIS

Front Suspension

- Single stage alloy steel taper leaf spring
- 1600x80x21 - 1 off, 1600x80x24 - 2 off
- Constant 285 N/mm
- Double acting shock absorbers with stabiliser bar

Rear Suspension

- Hendrickson HAS 400 air bag suspension
- Outboard mounted double acting hydraulic Shock absorbers
- 18,100kgs load capacity

Steering

- Power assisted recirculating ball
- Gear Ratio 22.4:1
- Turns lock-to-lock 5.4

Chassis Frame

- Cold riveted ladder frame
- Rail dimensions (mm) 258 x85 x 10
- HT540A weldable steel
- Parallel side rails

Brakes

- Meritor Q-Plus dual circuit, full air, S-cam drum brakes with auto-adjusting slack adjusters
- ABS
- Hill Start Aid
- Front drums 419mm x 127mm
- Rear drums 419mm x 178mm
- Spring park brake on rear wheels
- Air controlled exhaust brake
- Air dryer

Wheels and Tyres

- Rims: 22.5 x 8.25 x 165mm 10-stud steel wheels
- Tyres: 11.00R22.5 148/145 M tubeless tyres
- Frame mounted spare wheel with tyre

Electrical

- 24 volt negative earth system
- 60 amp alternator
- Batteries - 2 x 115E41L 80Ah. 665CCA @ 18°C

CAB AND INTERIOR

CAB EXTERIOR

- All steel construction, high tensile steel on cab under-frame and side impact beam reinforcement
- Cab is fully compliant with ECE-R29 crash tests
- Manual cab tilt to 45° with torsion bar assistance
- Liquid filled cab mounts
- Heavy duty non-slip cab entry steps
- 90° opening doors
- Door mounted 19" heated power mirrors, flat glass on main and convex on spot mirrors
- Air dam steel front bumper with integral fog lamps
- Halogen multi-reflector headlamps with integral turn signals
- Additional door-mounted turn signal indicators
- Roof-mounted outline marker lamps
- Combined brake/turn/reverse/marker lamps
- Registration plate lamps, extended wiring harness
- Reverse alarm buzzer standard

CAB INTERIOR

- Driver's seat - ISRI 6860 air suspended seat for occupant mass up to 150kg, pneumatic lumbar support, height, rake, auto weight adjustment
- Front passenger adjustable bucket seat and front centre seat with folding backrest, console in backrest

CAB INTERIOR (continued)

- 3-point ELR seatbelts with pre-tensioner in outboard seat positions, driver's seat belt fitted integral to the seat
- Centre seat has lap belt
- SRS including air bags on outer seat positions
- Door and pillar entry assist grips both sides
- Lined interior, padded roof lining and vinyl floor covers
- RH and LH overhead storage shelf
- Height/reach adjustable steering column, soft-feel urethane steering wheel
- Electric windows
- Central locking with keyless entry and engine immobiliser
- Twin cup holders, cigarette lighter
- Door mounted storage pockets, LH and RH glove boxes
- Centre console with storage tray, fold down storage tray in centre seat backrest
- Fluorescent interior lamp
- Multi Media radio/CD/DVD/MP3/WMA Player with 6.2" Touch Screen, Bluetooth, voice dialling, text to speech, SD and USB inputs, on-board recordable memory – optional external cameras with up to 4-way screen, GPS navigation and many other options
- 5 DIN sized compartments for extra communications and storage

INSTRUMENT AND CONTROLS

- Speedometer with digital odometer and two trip meters
- Tachometer, engine coolant temperature, fuel and dual brake air pressure gauges
- Two-speed wipers with intermittent wipe
- Key operated engine start, stop, steering lock
- HSA slow/fast engagement control with on/off switch
- DPD manual regenerate switch,
- **LH combination stalk:** windscreen wipers and washers exhaust brake
- **RH combination stalk:** Indicators, light switch, headlamp dip switch
- **Warning lamps:** Check engine, oil pressure, ABS, SRS, alternator charge, service brake, park brake on, seat belt, low air pressure, low fuel level water-in- fuel, cab lock
- Indicator lamps – HSA, warm up system, high beam, DPD status, exhaust brake, turn signals
- Multi info display shows service interval, instant and average fuel cons, DPD bar chart, hour meter voltmeter, time/day/date, 40-120 adjustable speed warning

Please refer to Owners and Drivers Manual for more detailed operation, driving instruction and warnings

WEIGHTS (kgs)

Model Code	MODEL	RATINGS *		LOADING LIMITS (at ground)*		CHASSIS CAB TARE MASS **		
		GVM	GCM ***	FRONT	REAR	FRONT	REAR	TOTAL
FV209	FVL 1350	18,000	32,000	6000	15,000	3410	3220	6630
FV203	FVL 1400	24,000	32,000	6000	15,000	3410	3220	6630

* Vehicle ratings and front and rear mass limits are subject to regulatory requirements – Consult your dealer to select a specific vehicle to suit your requirements

** Chassis cab as supplied from the factory including 10 litres of fuel

*** Vehicles equipped for towing trailers require modification to provide brake performance in accordance with Heavy Vehicle Brake Rule NZ32015

DIMENSIONS (mm)

Model	WB	OAL	OAH *	FOH	ROH	EA	CE	RT	ORT	FW	RFA *	BOC	Kerb to Kerb (m)
FVL 1350 & FVL1400	6470	11150	2810	1440	3240	5770	9085	1840	2445	850	1015	75	22.6

* Unladen condition, chassis cab only

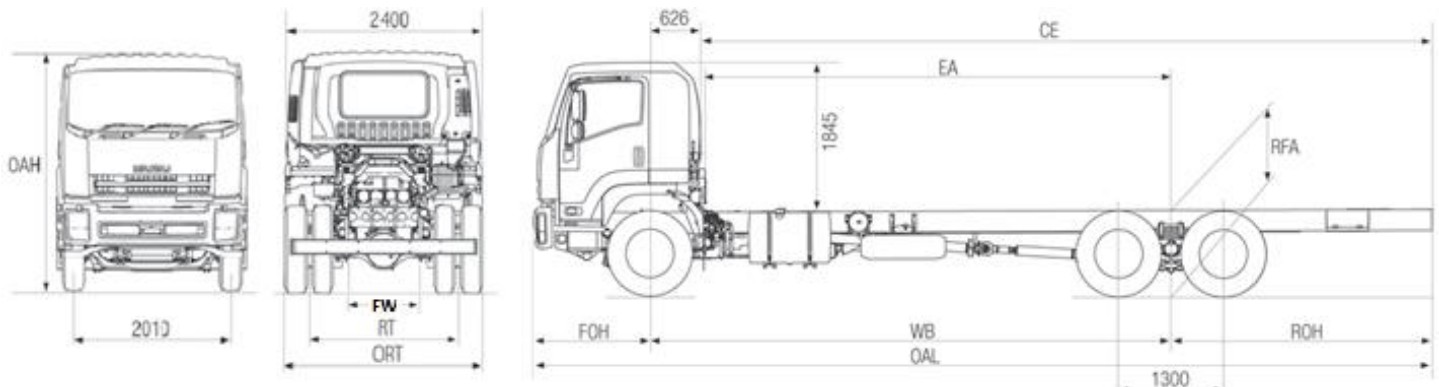

WARRANTY

Full vehicle warranty: 36 months or 200,000 kilometres whichever occurs first

All warranty is subject to terms and conditions as detailed in the Owner's Manual Service and Warranty Supplement

A policy of continuous improvement means that these specifications are subject to change without notice. Contact your Isuzu dealer or visit our website at Isuzu.co.nz to confirm specifications. Images of vehicles are representative only and may differ slightly from the actual vehicle