

Model	FTS800	FTS800P
GCM (kg)	26,500	26,500
GVM (kg)	13,900	13,900
Max Power (kW)	191	191
Max Torque (Nm)	760	760
Wheelbase (mm)	4250	4250
Suspension	Steel	Steel

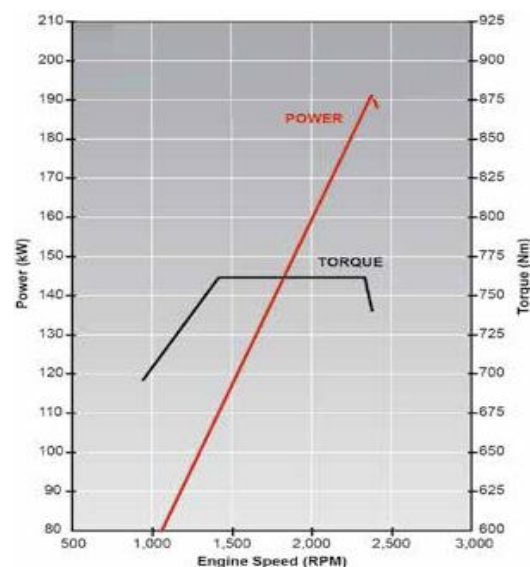

## ENGINE

Engine Model:	6HK1-TCC
Type:	6 cyl 24 valve, SOHC
Displacement:	7,790cc
Compression Ratio:	17.5:1
Max Power (DIN Nett):	191 kW (260 HP) @2,400 RPM
Max Torque (DIN Nett):	760 Nm (560 lb.ft) @1,450 - 2400 RPM
Emission Control System:	Euro V with Diesel Oxidation Catalyst (DOC)
Fuel System:	Electronically controlled direct injection, high pressure common rail 200 litre fuel tank with lockable fuel cap
Air Intake System:	Electronically controlled variable nozzle turbo charger with air-to-air Intercooler, vertical air intake behind cab



## PERFORMANCE

- Maximum Towed Mass (braked): 12,500kgs
- Maximum Towed Mass (unbraked): 2,000kgs
- 1<sup>st</sup> Gear Gradeability @GVM: 87%
- Est Engine RPM @90km/h : 1940

## TRANSMISSION

Manual:	MZW-6P 6 speed manual, synchromesh on 1 <sup>st</sup> to 6 <sup>th</sup> with air assisted shift
Clutch:	Air assisted hydraulic control, 381mm single plate clutch
PTO:	PTO Model: Flywheel PTO top of flywheel Standard: Opening left side of transmission case for fitment of PTO
Ratios (:1)	1 <sup>st</sup> 6.720, 2 <sup>nd</sup> 4.244, 3 <sup>rd</sup> 2.580, 4 <sup>th</sup> 1.540, 5 <sup>th</sup> 1.000, 6 <sup>th</sup> 0.763, Rev 6.823
Transfer Case:	Isuzu TF56 Full time 4WD with driver activated centre diff locks
Ratio:	High range: 1.00:1, Low range: 1.913:1

## AXLES

Front Axle:	Isuzu FDO47
Type :	Full floating banjo drive axle . Birfield outer joints and pemalantly engaged hubs.
Capacity:	4,700kgs
Rear Axle	Isuzu RO92
Type:	Full floating banjo drive axle.
Final Drive:	368mm diameter ring gear
Ratio:	5.875:1
Capacity:	9,200 kas

## CHASSIS

### Suspension (front)

- Single stage alloy steel taper leaf spring

### (back)

- Multi leaf main with helper

### Steering

- Power assisted recirculating ball
- Gear Ratio 16:1 – 18:1
- Turns lock-to-lock 4.1

### Chassis Frame

- Cold riveted ladder frame
- Rail dimensions (mm) 253 x85 x 7.5
- HT540A weldable steel
- Parallel side rails 850mm wide

### Brakes

- Dual circuit air over hydraulic auto-adjusting front and rear drum brakes
- ABS - switchable for off-road use
- Hill Start Aid (HAS) standard
- Front drums 410mm x 115mm
- Rear drums 410mm x 140mm
- Spring park brake on rear wheels
- Air controlled exhaust brake
- Air dryer

### Wheels and Tyres

- 11.00R22.5 tubeless tyres
- 22.5x7.5x165mm 8-stud steel wheel rims
- White painted wheel rims
- Frame mounted spare wheel with tyre

### Electrical

- 24 volt negative earth system
- Alternator: 60 amp
- Alternator PTO model 90 amp
- Batteries - 2 x 115E41L 80Ah, 665CCA @ 18°C

## CAB AND INTERIOR

### CAB EXTERIOR

- All steel construction, high tensile steel on cab under-frame and side impact beam reinforcement
- Cab is fully compliant with ECE-R29 crash tests
- Manual cab tilt to 45° with torsion bar assistance
- Liquid filled cab mounts
- 90° opening internally reinforced doors
- Door mounted 19" heated power mirrors, flat glass on main and convex on spot mirrors
- Air dam steel front bumper with integral fog lamps
- Halogen multi-reflector headlamps with integral turn signals
- Additional door-mounted turn signal indicators with cornering lamps
- Roof-mounted outline marker lamps
- Combined brake/turn/reverse/marker lamps

### CAB INTERIOR

- Driver's seat - ISRI 6870 air suspended seat for occupant mass up to 150kg, pneumatic lumbar support, height, rake, auto weight adjustment
- Front passenger adjustable bucket seat and front centre seat with folding backrest, console in backrest

### CAB INTERIOR (continued)

- SRS including air bag on both outer seats
- Door and pillar entry assist grips both sides
- Lined interior, padded roof lining and vinyl floor covers
- Manual control integrated air conditioning
- Height/reach adjustable steering column, soft-feel Urethane steering wheel
- Central locking with keyless entry and engine immobiliser
- Door mounted storage pockets, LH and RH glove boxes, RH and LH overhead storage shelf
- Centre console with storage tray
- Fluorescent interior lamp
- Multi Media radio/CD/DVD/MP3/WMA Player with 6.2" Touch Screen, Bluetooth, voice dialling, text to speech, SD and USB inputs, on-board recordable memory – optional external cameras with up to 4-way screen, GPS navigation and many other options
- 5 DIN sized compartments for extra communications and storage

### Instruments and Controls

- Speedometer with digital odometer and two trip meters
- Tachometer, engine coolant temperature, fuel level and dual brake air pressure gauges
- Two-speed wipers with intermittent wipe
- Key operated engine start, stop with steering lock
- High/Low range and centre diff lock
- ABS on/off switch
- HAS on/off and adjust switches
- Inter-axle lock switch
- LH combination stalk: windscreen wipers/wash exhaust brake
- RH combination stalk: Indicators, light switch, headlamp dip switch, cruise control
- Warning lamps: Check engine, oil pressure, ABS, SRS, alternator charge, service brake, park brake on, seat belt, low air pressure, water-in-fuel, low fuel level, cab lock.
- Indicator lamps: Warm up system, high beam, turn indicators, cruise control
- Multi display: shows service interval, instant and average fuel cons, voltmeter, hour meter, 40 – 120 kph adjustable speed warning, time/day/date

## WEIGHTS (kgs)

Model Code	MODEL	RATINGS *		LOADING LIMITS (at ground)*		CHASSIS CAB TARE MASS **		
		GVM	GCM ***	FRONT	REAR	FRONT	REAR	TOTAL
FT0716	FTS800	13,900	26,500	4700	9200	3030	2015	5045
FT0816	FTS800P	13,900	26,500	4700	9200	3095	2030	5125

\* Vehicle ratings and front and rear mass limits are subject to regulatory requirements – Consult your dealer to select a specific vehicle to suit your requirements

\*\* Chassis cab as supplied from the factory including 10 litres of fuel

## DIMENSIONS (mm)

Model	WB	OAL	OAH *	FOH	ROH	EA	CE	RT	ORT	FW	RFH *	BOC	Kerb to Kerb (m)
ALL	4250	7405	3090	1255	1900	2625	4648	1795	2365	850	1185	90	17.5

\* Unladen condition, chassis cab only

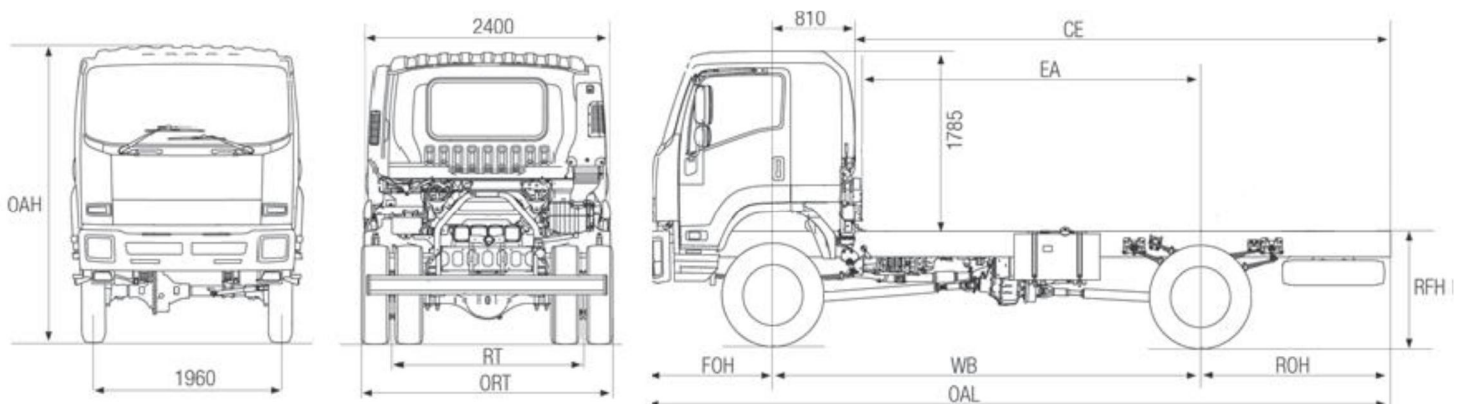

## WARRANTY

Full vehicle warranty: 36 months or 150,000 kilometres whichever occurs first

All warranty is subject to terms and conditions as detailed in the Owner's Manual Service and Warranty Supplement

A policy of continuous improvement means that these specifications are subject to change without notice. Contact your Isuzu dealer or visit our website at [Isuzu.co.nz](http://Isuzu.co.nz) to confirm specifications. Images of vehicles are representative only and may differ slightly from the actual vehicle