

Model	FTR750 Crew	FTR750 Crew AMT
GCM (kg)	24,000	24,000
GVM (kg)	15,000	15,000
Max Power (kW)	191	191
Max Torque (Nm)	760	760
Wheelbase (mm)	6050	6050
Suspension	Steel	Steel

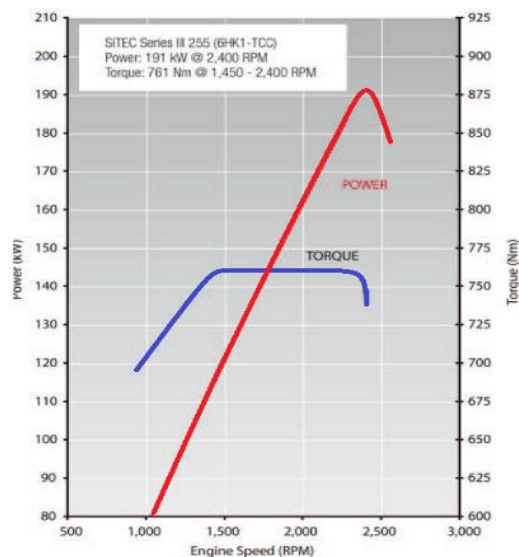

ENGINE

Engine Model:	6HK1-TCC
Type:	6 cyl 24 valve, SOHC
Displacement:	7,790cc
Compression Ratio:	17.5:1
Max Power (DIN Nett):	191 kW (260 HP) @2,400 RPM
Max Torque (DIN Nett):	760 Nm (560 lb.ft) @1,450 - 2400 RPM
Emission Control System:	Euro V with Diesel Oxidation Catalyst (DOC)
Fuel System:	Electronically controlled direct injection, high pressure common rail 200 litre fuel tank with lockable fuel cap
Air Intake System:	Electronically controlled variable nozzle turbo charger with air-to-air Intercooler, vertical air intake behind cab



PERFORMANCE

- Maximum Towed Mass (braked): 12,500kgs
- Maximum Towed Mass (unbraked): 2,000kgs
- 1st Gear Gradeability @GVM: 36%
- Est Engine RPM @90km/h : 2045

TRANSMISSION

Model:	MZW6P – 6 speed
Manual:	Synchromesh on 2 nd to 6 th with air assisted shift
Clutch:	Air assisted hydraulic control, 381mm single plate clutch
AMT:	Fully automated with sequential and manual shift modes, hydraulically controlled wet clutch and fluid coupling with lock-up and oil-to-air cooler
PTO:	Provision on LHS of transmission case, mainshaft driven
Ratios (:1)	1st 6.615, 2nd 4.095, 3rd 2.358, 4th 1.531, 5th 1.00, 6th 0.722, Rev 6.615

AXLES

Front Axle:	Isuzu F063
Type:	Elliot reverse I-beam
Capacity:	6300kgs
Rear Axle:	Isuzu R092/ Full floating banjo type housing
Capacity:	9200kgs
Ratio:	5.571:1

CHASSIS

Suspension

- (front)
- Single stage alloy steel taper leaf spring
- (back)
- Multi leaf main with helper

Steering

- Power assisted recirculating ball
- Gear Ratio 16:1 – 18:1
- Turns lock-to-lock 4.1

Chassis Frame

- Cold riveted ladder frame
- Rail dimensions (mm) 254 x 85 x 8
- HT540 weldable steel main rails
- Parallel side rails

Brakes

- Dual circuit, full air, taper roller front and rear auto-adjusting drum brakes
- ABS
- Hill Start Aid
- Front drum 410mm x 140mm
- Rear drum 410mm x 140mm
- Spring park brake on rear wheels
- Air dryer
- Air controlled exhaust brake

Wheels and Tyres

- 22.5x8.25x165mm 10-stud steel wheel rims
- 275/70 R22.5 148/145 M tubeless tyres
- Silver painted wheel rims
- Frame mounted spare wheel with tyre

Electrical

- 24 volt negative earth system
- 60 amp alternator
- Batteries - 2 x 115E41L 80Ah, 665CCA @ 18°C

CAB AND INTERIOR

CAB EXTERIOR

- All steel construction, high tensile steel on cab under-frame and side impact beam reinforcement
- Cab is fully compliant with ECE-R29 crash tests
- Manual cab tilt to 45° with torsion bar assistance
- Liquid filled cab mounts
- 90° opening internally reinforced doors
- Door mounted 19" heated power mirrors, flat glass on main and convex on spot mirrors
- Air dam steel front bumper with integral fog lamps
- Halogen multi-reflector headlamps with integral turn signals
- Additional door-mounted turn signal indicators with cornering lamps
- Roof-mounted outline marker lamps
- Combined brake/turn/reverse/marker lamps

CAB INTERIOR

- Driver's seat - ISRI 6860 air suspended seat for occupant mass up to 150kg, pneumatic lumbar support, height, rake, auto weight adjustment
- Front passenger adjustable bucket seat and front centre seat with folding backrest, console in backrest

CAB INTERIOR (continued)

- SRS including air bag on both outer seats
- Door and pillar entry assist grips both sides
- Lined interior, padded roof lining and vinyl floor covers
- Manual control integrated air conditioning
- Height/reach adjustable steering column, soft-feel Urethane steering wheel
- Central locking with keyless entry and engine immobiliser
- Door mounted storage pockets, LH and RH glove boxes, RH and LH overhead storage shelf
- Centre console with storage tray
- Fluorescent interior lamp
- Multi Media radio/CD/DVD/MP3/WMA Player with 6.2" Touch Screen, Bluetooth, voice dialling, text to speech, SD and USB inputs, on-board recordable memory – optional external cameras with up to 4-way screen, GPS navigation and many other options
- 5 DIN sized compartments for extra communications and storage

Instruments and Controls

- Tachometer, engine coolant temperature, fuel and dual brake air pressure gauges
- Two-speed wipers with intermittent wipe
- Key operated engine start, stop and steering lock
- HSA slow/fast engagement control with on/off switch
- ASR on/off switch
- **LH combination stalk:** windscreen wipers/wash exhaust brake
- **RH combination stalk:** Indicators, light switch, headlamp dip switch, cruise control
- **Warning lamps:** Check engine, oil pressure, ABS, SRS, alternator charge, service brake, park brake on, seat belt, low air pressure, water-in-fuel, air suspension fault (FRD), low fuel level, cab lock.
- **Indicator lamps:** HSA, warm up system, high beam, SRS, 1st gear start,
- **AMT only:** AMT check light, AMT slow/fast, clutch engagement control, 1st gear selection, gear selection indicator display, cruise control, economy mode switch,
- **Multi display:** shows service interval, instant and average fuel cons, voltmeter, hour meter, 40 – 120 kph adjustable speed warning, time/day/date

WEIGHTS (kgs)

Model code	MODELS	RATINGS *		LOADING LIMITS (at ground)*		CHASSIS CAB TARE MASS **		
		GVM	GCM ***	FRONT	REAR	FRONT	REAR	TOTAL
FT0516	FTR750 Crew	15,000	24,000	6000	8200	3375	1885	5260
FT0616	FTR750 Crew AMT	15,000	24,000	6000	8200	3085	1885	5270

* Vehicle ratings and front and rear mass limits are subject to regulatory requirements – Consult your dealer to select a specific vehicle to suit your requirements

** Chassis cab as supplied from the factory including 10 litres of fuel

DIMENSIONS (mm)

Models	WB	OAL	CH *	FOH	ROH	EA	CE	RT	ORT	FW	RFA *	Kerb to Kerb (m)
FTR750 Crew & Crew AMT	6050	10005	2875	1440	2515	4625	7248	1820	2430	850	1025	20.1

* Unladen, chassis cab only

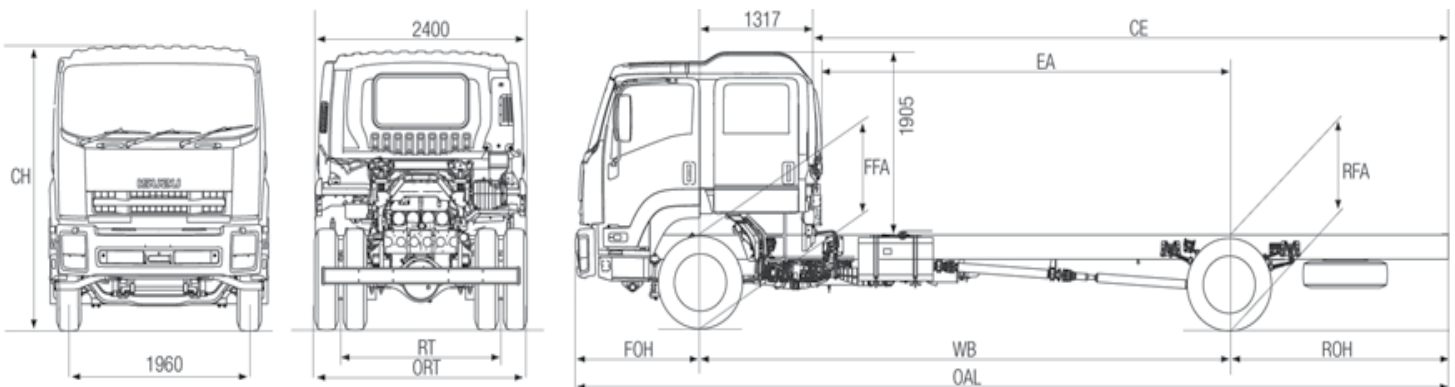

WARRANTY

Full vehicle warranty: 36 months or 150,000 kilometres whichever occurs first

All warranty is subject to terms and conditions as detailed in the Owner's Manual Service and Warranty Supplement

A policy of continuous improvement means that these specifications are subject to change without notice. Contact your Isuzu dealer or visit our website at Isuzu.co.nz to confirm specifications. Images of vehicles are representative only and may differ slightly from the actual vehicle