

Model	FSR700	FSR700 AMT/Auto	FSR700M Auto
GCM (kg)	20,000	20,000	20,000
GVM (kg)	14,000	14,000	14,000
Max Power (kW)	191	191	191
Max Torque (Nm)	760	760	760
Wheelbase (mm)	5560	5560	3790
Suspension	Steel	Steel	Steel

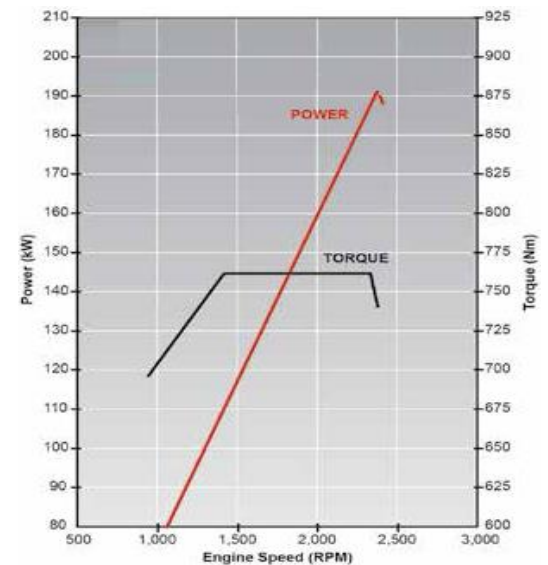

ENGINE

Engine Model:	6HK1-TCC
Type:	6 cyl 24 valve, SOHC
Displacement:	7,790cc
Compression Ratio:	17.5:1
Max Power (DIN Nett):	191 kW (260 HP) @2,400 RPM
Max Torque (DIN Nett):	760 Nm (560 lb.ft) @1,450 - 2400 RPM
Emission Control System:	Euro V with Diesel Oxidation Catalyst (DOC)
Fuel System:	Electronically controlled direct injection, high pressure common rail 200 litre fuel tank with lockable fuel cap
Air Intake System:	Electronically controlled variable nozzle turbo charger with air-to-air Intercooler, vertical air intake behind cab



PERFORMANCE

- Maximum Towed Mass (braked): 12,000kgs 1st Gear Gradeability @GVM: 45%, Auto 38%
- Maximum Towed Mass (unbraked): 2,000kgs Est Engine RPM @90km/h: 2135, Auto 2000

TRANSMISSION

Manual:	MZW-6P (standard)
AMT:	6 spd - fully automated with automatic and sequential manual shift modes, hydraulically controlled wet clutch and fluid coupling with lock-up and oil-to-air cooler (optional)
Ratios (:1)	1st 6.615, 2nd 4.095, 3rd 2.358, 4th 1.531, 5th 1.00, 6th 0.722, Rev 6.615
Auto:	Allison LCT2500 (optional)
Ratios (:1)	1 st : 3.51, 2 nd : 1.90, 3 rd : 1.44, 4 th : 1.00, 5 th : 0.74, 6 th : 0.64, Rev 5.09
PTO:	Provision on LHS of transmission case, main shaft driven

AXLES

Front Axle:	Isuzu F050
Type:	Elliot reverse I-beam
Capacity:	5000kgs
Rear Axle:	Isuzu R077 / Full floating banjo type housing
Capacity:	9000kgs
Ratio:	4.875:1

CHASSIS

Front Suspension

- Single stage alloy steel taper leaf spring
- Double acting hydraulic shock absorbers.
Stabiliser bar.

Rear Suspension

- Multi leaf main spring with helper

Chassis Frame

- Cold riveted ladder frame
- Rail dimensions (mm) 225 x 70 x 6
- HT540 weldable steel main rails
- Parallel side rails 840mm wide

Steering

- Power assisted recirculating ball
- Gear Ratio 16:1 – 18:1
- Turns lock-to-lock 4.1

Brakes

- Dual circuit air-over-hydraulic front and rear auto-adjusting drum
- ABS with Traction Control
- Hill Start Aid
- Front drum 320mm x 120mm
- Rear drum 320mm x 145mm
- Spring park brake on rear wheels
- Air dryer
- Air controlled exhaust brake

Wheels and Tyres

- 19.5x6.75x147mm 8-stud steel wheel rims
- 265/70 R19.5 140/138M tubeless tyres
- Silver painted wheel rims
- Frame mounted spare wheel with tyre

Electrical

- 24 volt negative earth system
- 60 amp alternator
- Batteries - 2 x 115E41L 80Ah, 665CCA @ 18°C

CAB AND INTERIOR

CAB EXTERIOR

- All steel construction, high tensile steel on cab under-frame and side impact beam reinforcement
- Cab is fully compliant with ECE-R29 crash tests
- Manual cab tilt to 45° with torsion bar assistance
- Liquid filled cab mounts
- 90° opening internally reinforced doors
- Door mounted 19" heated power mirrors, flat glass on main and convex on spot mirrors
- Air dam steel front bumper with integral fog lamps
- Halogen multi-reflector headlamps with integral turn signals
- Additional door-mounted turn signal indicators with cornering lamps
- Roof-mounted outline marker lamps
- Combined brake/turn/reverse/marker lamps

CAB INTERIOR

- Driver's seat - ISRI 6860 air suspended seat for occupant mass up to 150kg, pneumatic lumbar support, height, rake, auto weight adjustment
- Front passenger adjustable bucket seat and front centre seat with folding backrest, console in backrest

CAB INTERIOR (continued)

- SRS including air bag on both outer seats
- Door and pillar entry assist grips both sides
- Lined interior, padded roof lining and vinyl floor covers
- Manual control integrated air conditioning
- Height/reach adjustable steering column, soft-feel Urethane steering wheel
- Central locking with keyless entry and engine immobiliser
- Door mounted storage pockets, LH and RH glove boxes, RH and LH overhead storage shelf
- Centre console with storage tray
- Fluorescent interior lamp
- Multi Media radio/CD/DVD/MP3/WMA Player with 6.2" Touch Screen, Bluetooth, voice dialling, text to speech, SD and USB inputs, on-board recordable memory – optional external cameras with up to 4-way screen, GPS navigation and many other options
- 5 DIN sized compartments for extra communications and storage

Instruments and Controls

- Speedometer with digital odometer and two trip meters
- Tachometer, engine coolant temperature, fuel level and dual brake air pressure gauges
- Two-speed wipers with intermittent wipe
- Key operated engine start, stop with steering lock
- **LH combination stalk:** windscreen wipers/wash exhaust brake
- **RH combination stalk:** Indicators, light switch, headlamp dip switch, cruise control
- **Warning lamps:** Check engine, oil pressure, ABS, SRS, alternator charge, service brake, park brake on, seat belt, low air pressure, water-in-fuel, low fuel level, cab lock.
- **Indicator lamps:** Warm up system, high beam, turn indicators, cruise control
- **Multi display:** shows service interval, instant and average fuel cons, voltmeter, hour meter, 40 – 120 kph adjustable speed warning, time/day/date

WEIGHTS (kgs)

Models	Model Code	RATINGS *		LOADING LIMITS (at ground)*		CHASSIS CAB TARE MASS **		
		GVM	GCM	FRONT	REAR	FRONT	REAR	TOTAL
FSR700	FS0116	14,000	20,000	5000	8200	2450	1450	3900
FSR700 AMT	FS0216	14,000	20,000	5000	8200	2465	1455	3920
FSR700 M Auto	FS2016	14,000	20,000	5000	8200	TBA	TBA	TBA
FSR700 L Auto	FS2116	14,000	20,000	5000	8200	2575	1465	4040

* Vehicle ratings and front and rear mass limits are subject to regulatory requirements – Consult your dealer to select a specific vehicle to suit your requirements

** Chassis cab as supplied from the factory including 10 litres of fuel

DIMENSIONS (mm)

Models	WB	OAL	OAH *	FOH	ROH	EA	CE	RT	ORT	FW	RFH *	BOC	Kerb to Kerb (m)
FSR700/AMT/L Auto	5560	9155	2665	1170	2425	4575	7090	1660	2215	840	885	90	19.9
FSR700 M Auto	3790	6555	2665	1170	1595	2894	4489	1705	2215	840	885	90	19.9

* Unladen condition

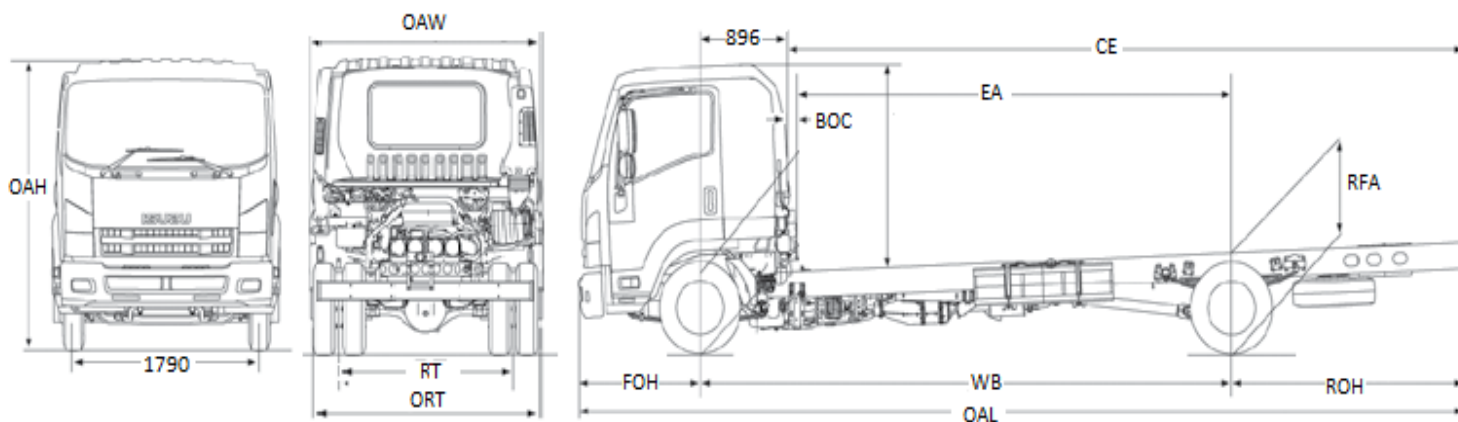

WARRANTY

Full vehicle warranty: 36 months or 150,000 kilometres whichever occurs first

All warranty is subject to terms and conditions as detailed in the Owner's Manual Service and Warranty Supplement

A policy of continuous improvement means that these specifications are subject to change without notice. Contact your Isuzu dealer or visit our website at Isuzu.co.nz to confirm specifications. Images of vehicles are representative only and may differ slightly from the actual vehicle