

Model	FSR650	FSR650 Auto	FSR650 AMT
GCM (kg)	20,000	20,000	20,000
GVM (kg)	12,000	12,000	12,000
Max Power (kW)	191	191	191
Max Torque (Nm)	760	760	760
Wheelbase (mm)	5560	3790/5560	5560
Suspension	Steel	Steel	Steel



## ENGINE

<b>Engine Model:</b>	6HK1-TCC
<b>Type:</b>	6 cyl 24 valve, SOHC
<b>Displacement:</b>	7,790cc
<b>Compression Ratio:</b>	17.5:1
<b>Max Power (DIN Nett):</b>	191 kW (260 HP) @2,400 RPM
<b>Max Torque (DIN Nett):</b>	760 Nm (560 lb.ft) @1,450 - 2400 RPM
<b>Emission Control System:</b>	Euro V with Diesel Oxidation Catalyst (DOC)
<b>Fuel System:</b>	Electronically controlled direct injection, high pressure common rail 200 litre fuel tank with lockable fuel cap
<b>Air Intake System:</b>	Electronically controlled variable nozzle turbo charger with air-to-air Intercooler, vertical air intake behind cab

## PERFORMANCE

- **Maximum Towed Mass (braked):** 12,000kgs    **1st Gear Gradability @GVM:** 55% Auto 38%
- **Maximum Towed Mass (unbraked):** 2,000kgs    **Est Engine RPM @90km/h:** 2135 Auto 2000

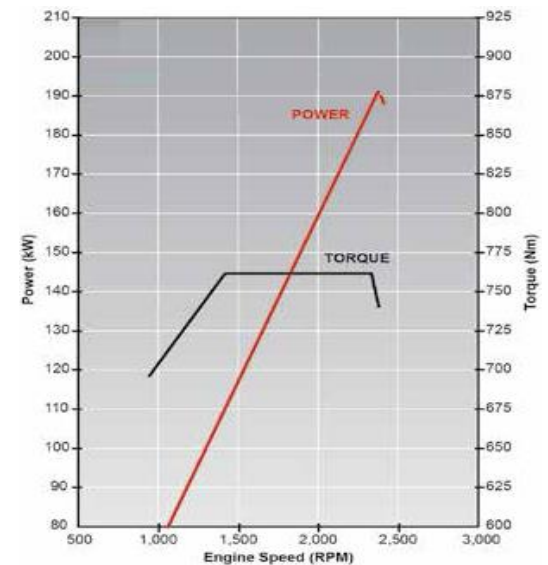

## TRANSMISSION

<b>Manual:</b>	MZW-6P (standard)
<b>AMT:</b>	6 spd - fully automated with automatic and sequential manual shift modes, hydraulically controlled wet clutch and fluid coupling with lock-up and oil-to-air cooler (optional)
<b>Ratios (:1)</b>	1st 6.615, 2nd 4.095, 3rd 2.358, 4th 1.531, 5th 1.00, 6th 0.722, Rev 6.615
<b>Auto:</b>	Allison LCT2500 (optional)
<b>Ratios (:1)</b>	1st: 3.51, 2nd: 1.90, 3rd: 1.44, 4th: 1.00, 5th: 0.74, 6th: 0.64, Rev 5.09
<b>PTO:</b>	Provision on LHS of transmission case, main shaft driven

## AXLES

<b>Front Axle:</b>	Isuzu F050
<b>Type:</b>	Elliot reverse I-beam
<b>Capacity:</b>	5000kgs
<b>Rear Axle:</b>	Isuzu R077 / Full floating banjo type housing
<b>Capacity:</b>	9000kgs
<b>Ratio:</b>	4.875:1

## CHASSIS

### Front Suspension

- Single stage alloy steel taper leaf spring
- Double acting hydraulic shock absorbers. Stabiliser bar.

### Rear Suspension

- Multi leaf main spring with helper

### Chassis Frame

- Cold riveted ladder frame
- Rail dimensions (mm) 225 x 70 x 6
- HT540 weldable steel main rails
- Parallel side rails 840mm wide

### Steering

- Power assisted recirculating ball
- Gear Ratio 16:1 – 18:1
- Turns lock-to-lock 4.1

### Brakes

- Dual circuit air-over-hydraulic front and rear auto-adjusting drum
- ABS with Traction Control
- Hill Start Aid
- Front drum 320mm x 120mm
- Rear drum 320mm x 145mm
- Spring park brake on rear wheels
- Air dryer
- Air controlled exhaust brake

### Wheels and Tyres

- 19.5x6.75x147mm 8-stud steel wheel rims
- 265/70 R19.5 140/138M tubeless tyres
- Silver painted wheel rims
- Frame mounted spare wheel with tyre

### Electrical

- 24 volt negative earth system
- 60 amp alternator
- Batteries - 2 x 115E41L 80Ah, 665CCA @ 18°C

## CAB AND INTERIOR

### CAB EXTERIOR

- All steel construction, high tensile steel on cab under-frame and side impact beam reinforcement
- Cab is fully compliant with ECE-R29 crash tests
- Manual cab tilt to 45° with torsion bar assistance
- Liquid filled cab mounts
- 90° opening internally reinforced doors
- Door mounted 19" heated power mirrors, flat glass on main and convex on spot mirrors
- Air dam steel front bumper with integral fog lamps
- Halogen multi-reflector headlamps with integral turn signals
- Additional door-mounted turn signal indicators with cornering lamps
- Roof-mounted outline marker lamps
- Combined brake/turn/reverse/marker lamps

### CAB INTERIOR

- Driver's seat - ISRI 6860 air suspended seat for occupant mass up to 150kg, pneumatic lumbar support, height, rake, auto weight adjustment
- Front passenger adjustable bucket seat and front centre seat with folding backrest, console in backrest

### CAB INTERIOR (continued)

- SRS including air bag on both outer seats
- Door and pillar entry assist grips both sides
- Lined interior, padded roof lining and vinyl floor covers
- Manual control integrated air conditioning
- Height/reach adjustable steering column, soft-feel Urethane steering wheel
- Central locking with keyless entry and engine immobiliser
- Door mounted storage pockets, LH and RH glove boxes, RH and LH overhead storage shelf
- Centre console with storage tray
- Fluorescent interior lamp
- Multi Media radio/CD/DVD/MP3/WMA Player with 6.2" Touch Screen, Bluetooth, voice dialling, text to speech, SD and USB inputs, on-board recordable memory – optional external cameras with up to 4-way screen, GPS navigation and many other options
- 5 DIN sized compartments for extra communications and storage

### Instruments and Controls

- Speedometer with digital odometer and two trip meters
- Tachometer, engine coolant temperature, fuel level and dual brake air pressure gauges
- Two-speed wipers with intermittent wipe
- Key operated engine start, stop with steering lock
- **LH combination stalk:** windscreen wipers/wash exhaust brake
- **RH combination stalk:** Indicators, light switch, headlamp dip switch, cruise control
- **Warning lamps:** Check engine, oil pressure, ABS, SRS, alternator charge, service brake, park brake on, seat belt, low air pressure, water-in-fuel, low fuel level, cab lock.
- **Indicator lamps:** Warm up system, high beam, turn indicators, cruise control
- **Multi display:** shows service interval, instant and average fuel cons, voltmeter, hour meter, 40 – 120 kph adjustable speed warning, time/day/date

## WEIGHTS (kgs)

Models	Model Code	RATINGS *		LOADING LIMITS (at ground)*		CHASSIS CAB TARE MASS **		
		GVM	GCM	FRONT	REAR	FRONT	REAR	TOTAL
FSR650	FS1116	12,000	20,000	5000	8200	2450	1450	3900
FSR650 AMT	FS1216	12,000	20,000	5000	8200	2465	1455	3920
FSR650 Auto	FS2416	12,000	20,000	5000	8200	2575	1465	4040
FSR650 Auto	FS2316	12,000	20,000	5000	8200	TBA	TBA	TBA

\* Vehicle ratings and front and rear mass limits are subject to regulatory requirements – Consult your dealer to select a specific vehicle to suit your requirements

\*\* Chassis cab as supplied from the factory including 10 litres of fuel

## DIMENSIONS (mm)

Models	WB	OAL	OAH *	FOH	ROH	EA	CE	RT	ORT	FW	RFH *	BOC	Kerb to Kerb (m)
FSR650 and AMT	5560	9155	2665	1170	2425	4575	7090	1660	2215	840	885	90	19.9
FSR650 Auto	5560	9155	2665	1170	2425	4575	7090	1705	2215	840	885	90	19.9

\* Unladen condition

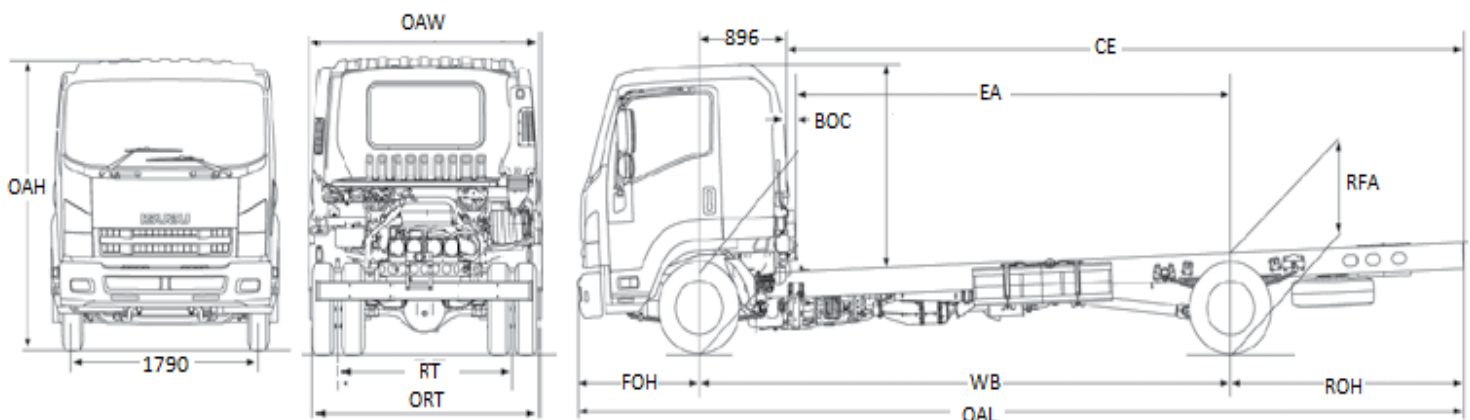

## WARRANTY

**Full vehicle warranty:** 36 months or 150,000 kilometres whichever occurs first

All warranty is subject to terms and conditions as detailed in the Owner's Manual Service and Warranty Supplement

A policy of continuous improvement means that these specifications are subject to change without notice. Contact your Isuzu dealer or visit our website at [Isuzu.co.nz](http://Isuzu.co.nz) to confirm specifications. Images of vehicles are representative only and may differ slightly from the actual vehicle