

| Model | FSD650 | FSD650 Auto | FSD650 AMT |
|-----------------|--------|-------------|------------|
| GCM (kg) | 20,000 | 20,000 | 20,000 |
| GVM (kg) | 12,000 | 12,000 | 12,000 |
| Max Power (kW) | 191 | 191 | 191 |
| Max Torque (Nm) | 760 | 760 | 760 |
| Wheelbase (mm) | 5560 | 5560 | 5560 |
| Suspension | Air | Air | Air |



ENGINE

| | |
|---------------------------------|--|
| Engine Model: | 6HK1-TCC |
| Type: | 6 cyl 24 valve, SOHC |
| Displacement: | 7,790cc |
| Compression Ratio: | 17.5:1 |
| Max Power (DIN Nett): | 191 kW (260 HP) @2,400 RPM |
| Max Torque (DIN Nett): | 760 Nm (560 lb.ft) @1,450 - 2400 RPM |
| Emission Control System: | Euro V with Diesel Oxidation Catalyst (DOC) |
| Fuel System: | Electronically controlled direct injection, high pressure common rail 200 litre fuel tank with lockable fuel cap |
| Air Intake System: | Electronically controlled variable nozzle turbo charger with air-to-air Intercooler, vertical air intake behind cab |

PERFORMANCE

- **Maximum Towed Mass (braked):** 12,000kgs **1st Gear Gradeability @GVM:** 45% Auto 38%
- **Maximum Towed Mass (unbraked):** 2,000kgs **Est Engine RPM @90km/h:** 2135 Auto 2000

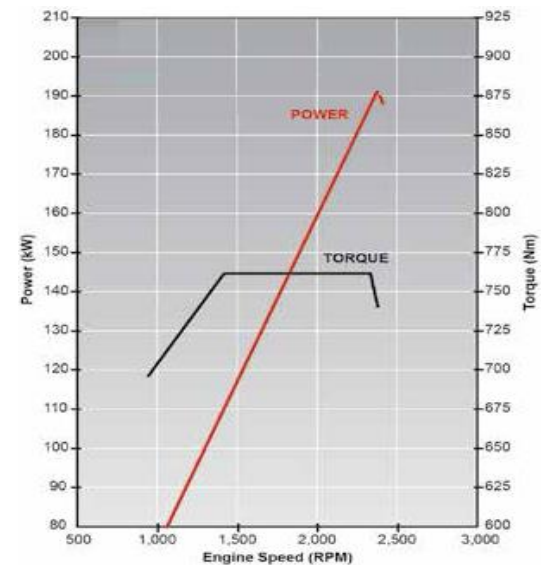

TRANSMISSION

| | |
|--------------------|--|
| Manual: | MZW-6P (standard) |
| AMT: | 6 spd - fully automated with automatic and sequential manual shift modes, hydraulically controlled wet clutch and fluid coupling with lock-up and oil-to-air cooler (optional) |
| Ratios (:1) | 1st 6.615, 2nd 4.095, 3rd 2.358, 4th 1.531, 5th 1.00, 6th 0.722, Rev 6.615 |
| Auto: | Allison LCT2500 (optional) |
| Ratios (:1) | 1st: 3.51, 2nd: 1.90, 3rd: 1.44, 4th: 1.00, 5th: 0.74, 6th: 0.64, Rev 5.09 |
| PTO: | Provision on LHS of transmission case, main shaft driven |

AXLES

| | |
|--------------------|---|
| Front Axle: | Isuzu F050 |
| Type: | Elliot reverse I-beam |
| Capacity: | 5000kgs |
| Rear Axle: | Isuzu R077 / Full floating banjo type housing |
| Capacity: | 9000kgs |
| Ratio: | 4.875:1 |

CHASSIS

Front Suspension

- Single stage alloy steel taper leaf spring
- Double acting hydraulic shock absorbers.
Stabiliser bar.

Rear Suspension

- Hendrickson HAS200 air suspension
- Outboard mounted shock absorbers

Chassis Frame

- Cold riveted ladder frame
- Rail dimensions (mm) 225 x 70 x 6
- HT540 weldable steel main rails
- Parallel side rails 840mm wide

Steering

- Power assisted recirculating ball
- Gear Ratio 16:1 – 18:1
- Turns lock-to-lock 4.1

Brakes

- Dual circuit air-over-hydraulic front and rear auto-adjusting drum
- ABS with Traction Control
- Hill Start Aid
- Front drum 320mm x 120mm
- Rear drum 320mm x 145mm
- Spring park brake on rear wheels
- Air dryer
- Air controlled exhaust brake

Wheels and Tyres

- 19.5x6.75x147mm 8-stud steel wheel rims
- 265/70 R19.5 140/138M tubeless tyres
- Silver painted wheel rims
- Frame mounted spare wheel with tyre

Electrical

- 24 volt negative earth system
- 60 amp alternator
- Batteries - 2 x 115E41L 80Ah, 665CCA @ 18°C

CAB AND INTERIOR

CAB EXTERIOR

- All steel construction, high tensile steel on cab under-frame and side impact beam reinforcement
- Cab is fully compliant with ECE-R29 crash tests
- Manual cab tilt to 45° with torsion bar assistance
- Liquid filled cab mounts
- 90° opening internally reinforced doors
- Door mounted 19" heated power mirrors, flat glass on main and convex on spot mirrors
- Air dam steel front bumper with integral fog lamps
- Halogen multi-reflector headlamps with integral turn signals
- Additional door-mounted turn signal indicators with cornering lamps
- Roof-mounted outline marker lamps
- Combined brake/turn/reverse/marker lamps

CAB INTERIOR

- Driver's seat - ISRI 6860 air suspended seat for occupant mass up to 150kg, pneumatic lumbar support, height, rake, auto weight adjustment
- Front passenger adjustable bucket seat and front centre seat with folding backrest, console in backrest

CAB INTERIOR (continued)

- SRS including air bag on both outer seats
- Door and pillar entry assist grips both sides
- Lined interior, padded roof lining and vinyl floor covers
- Manual control integrated air conditioning
- Height/reach adjustable steering column, soft-feel Urethane steering wheel
- Central locking with keyless entry and engine immobiliser
- Door mounted storage pockets, LH and RH glove boxes, RH and LH overhead storage shelf
- Centre console with storage tray
- Fluorescent interior lamp
- Multi Media radio/CD/DVD/MP3/WMA Player with 6.2" Touch Screen, Bluetooth, voice dialling, text to speech, SD and USB inputs, on-board recordable memory – optional external cameras with up to 4-way screen, GPS navigation and many other options
- 5 DIN sized compartments for extra communications and storage

Instruments and Controls

- Speedometer with digital odometer and two trip meters
- Tachometer, engine coolant temperature, fuel level and dual brake air pressure gauges
- Two-speed wipers with intermittent wipe
- Key operated engine start, stop with steering lock
- **LH combination stalk:** windscreen wipers/wash exhaust brake
- **RH combination stalk:** Indicators, light switch, headlamp dip switch, cruise control
- **Warning lamps:** Check engine, oil pressure, ABS, SRS, alternator charge, service brake, park brake on, seat belt, low air pressure, water-in-fuel, low fuel level, cab lock.
- **Indicator lamps:** Warm up system, high beam, turn indicators, cruise control
- **Multi display:** shows service interval, instant and average fuel cons, voltmeter, hour meter, 40 – 120 kph adjustable speed warning, time/day/date

WEIGHTS (kgs)

| Models | Model Code | RATINGS * | | LOADING LIMITS (at ground)* | | CHASSIS CAB TARE MASS ** | | |
|-------------|------------|-----------|--------|-----------------------------|------|--------------------------|------|-------|
| | | GVM | GCM | FRONT | REAR | FRONT | REAR | TOTAL |
| FSD650 | FS0316 | 12,000 | 20,000 | 5000 | 8200 | 2450 | 1450 | 3900 |
| FSD650 AMT | FS0416 | 12,000 | 20,000 | 5000 | 8200 | 2465 | 1455 | 3920 |
| FSD650 Auto | FS2516 | 12,000 | 20,000 | 5000 | 8200 | 2550 | 1505 | 4055 |

* Vehicle ratings and front and rear mass limits are subject to regulatory requirements – Consult your dealer to select a specific vehicle to suit your requirements

** Chassis cab as supplied from the factory including 10 litres of fuel

DIMENSIONS (mm)

| Models | WB | OAL | OAH * | FOH | ROH | EA | CE | RT | ORT | FW | RFH * | Kerb to Kerb (m) |
|--------------|------|------|-------|------|------|------|------|------|------|-----|-------|------------------|
| FSD650 & AMT | 5560 | 9155 | 2590 | 1170 | 2425 | 4575 | 7090 | 1660 | 2215 | 840 | 790 | 19.9 |
| FSD650 Auto | 5560 | 9155 | 2665 | 1170 | 2425 | 4575 | 7090 | 1705 | 2215 | 840 | 850 | 19.9 |

* Unladen condition

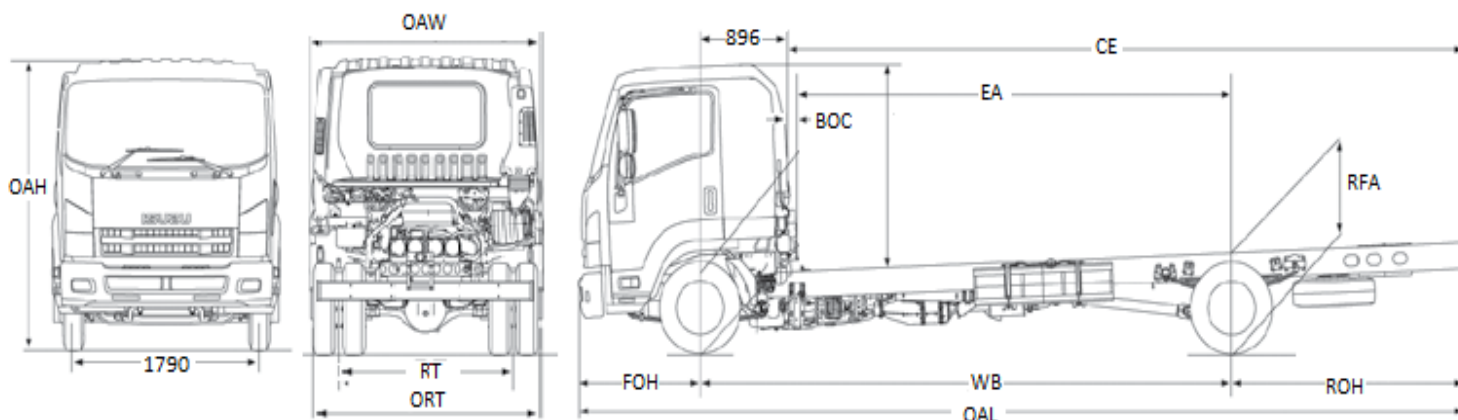

WARRANTY

Full vehicle warranty: 36 months or 150,000 kilometres whichever occurs first

All warranty is subject to terms and conditions as detailed in the Owner's Manual Service and Warranty Supplement

A policy of continuous improvement means that these specifications are subject to change without notice. Contact your Isuzu dealer or visit our website at Isuzu.co.nz to confirm specifications. Images of vehicles are representative only and may differ slightly from the actual vehicle