

Model	FRR500
GVM (kg)	10,700
GCM (kg)	16,000
Max Power (kW)	151
Max Torque (Nm)	637
Wheelbase (mm)	3790
Suspension	Steel

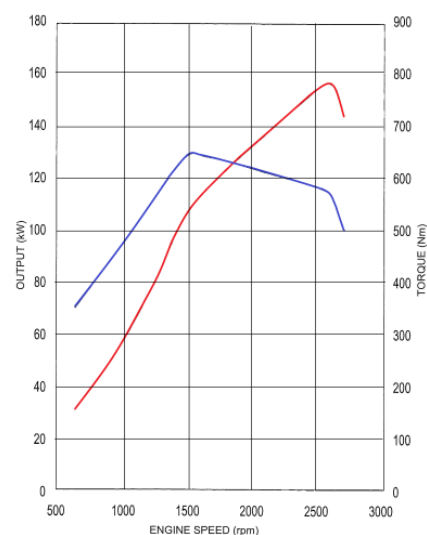

ENGINE

Engine Model:	4HK1-TCS
Type:	4 cyl 24 valve, SOHC
Displacement:	5,193cc
Compression Ratio:	17.5:1
Max Power (DIN Nett):	151 kW (205 HP) @2,600 RPM
Max Torque (DIN Nett):	637 Nm (470 lb.ft) @1,600 RPM
Emission Control System:	Euro V with Exhaust Gas Retention & Diesel Particulate Filter
Fuel System:	Electronically controlled direct injection, high pressure common rail 200 litre fuel tank with lockable fuel cap
Air Intake System:	Electronically controlled variable nozzle turbo charger with air-to-air Intercooler, vertical air intake behind cab



PERFORMANCE

- Maximum Towed Mass (braked): 5,600kgs
- Maximum Towed Mass (unbraked): 2,000kgs
- 1st Gear Gradability @GVM: 62%
- Est Engine RPM @90km/h : 2080

TRANSMISSION

Manual:	MZW-6P (standard)
AMT:	6 spd - fully automated with automatic and sequential manual shift modes, hydraulically controlled wet clutch and fluid coupling with lock-up and oil-to-air cooler (optional)
Ratios (:1)	1st 6.615, 2nd 4.095, 3rd 2.358, 4th 1.531, 5th 1.00, 6th 0.722, Rev 6.615
PTO:	Provision on LHS of transmission case, main shaft driven

AXLES

Front Axle:	Isuzu F041
Type:	Elliot reverse I-beam
Capacity:	4100kgs
Rear Axle:	Isuzu R077 / Full floating banjo type housing
Capacity:	7700kgs
Ratio:	5.125:1

CHASSIS

Front Suspension

- Single stage alloy steel taper leaf spring
- Double acting hydraulic shock absorbers.
- Stabiliser bar

Rear Suspension

- Multi leaf main spring with helper

Chassis Frame

- Cold riveted ladder frame
- Rail dimensions (mm) 225 x 70 x 6
- HT540 weldable steel main rails
- Parallel side rails 840mm wide

Steering

- Power assisted recirculating ball
- Gear Ratio 16:1 – 18:1
- Turns lock-to-lock 4.1

Brakes

- Dual circuit air-over-hydraulic front and rear auto-adjusting drum
- ABS with Traction Control
- Hill Start Aid
- Front drum 320mm x 120mm
- Rear drum 320mm x 145mm
- Spring park brake on rear wheels
- Air dryer
- Air controlled exhaust brake

Wheels and Tyres

- 17.5x6.75x135mm 6-stud steel wheel rims
- 235/75R17.5 132/130M tubeless tyres
- Silver painted wheel rims
- Frame mounted spare wheel with tyre

Electrical

- 24 volt negative earth system
- 60 amp alternator
- Batteries - 2 x 115E41L 80Ah, 665CCA @ 18°C

CAB AND INTERIOR

CAB EXTERIOR

- Cab is fully compliant with ECE-R29 crash tests
- Manual cab tilt to 45° with torsion bar assistance
- Liquid filled cab mounts
- Heavy duty non-slip cab entry steps
- 90° opening doors, entry assist handles
- Door mounted 19" heated power mirrors, flat glass on main and convex on spot mirrors
- Halogen multi-reflector headlamps with integral fog lamps & turn signals
- Roof-mounted outline marker lamps
- Combined brake/turn/reverse/marker lamps
- Reverse alarm buzzer standard

TIPPER BODY

- All steel body with drop sides. Auto release two-way tailgate.
- Auto release body lockdown hook.
- Shovel rack. LHS and RHS rope rails. Non-slip side steps.
- 20 second raise / 20 second lower time.
- Cubic volume: 3.8 m³
- Deck plate thickness: 6.0 mm
- Side / front / tail plate thickness: 3.2mm

CAB INTERIOR

- Driver's seat - ISRI 6860 air suspended seat for occupant mass up to 150kg, pneumatic lumbar support, height, rake, auto weight adjustment
- Front passenger adjustable seat & front centre seat with folding backrest, console in backrest
- SRS including air bag on both outer seats
- Interior, padded roof lining and vinyl floor covers
- Manual control integrated air conditioning
- Height/reach adjustable steering column, soft-feel Urethane steering wheel
- Central locking with keyless entry & engine immobiliser
- Door mounted storage pockets, LH & RH glove boxes, over-head storage shelf
- Centre console with storage tray
- Multi Media radio/CD/DVD/MP3/WMA Player with 6.2" Touch Screen, Bluetooth, voice dialling, text to speech, SD and USB inputs, on-board recordable memory – optional external cameras with up to 4-way screen, GPS navigation and many other options
- 5 DIN sized compartments for extra communications and storage

Instruments and Controls

- Speedometer with digital odometer and two trip meters
- Tacho, engine coolant temp, fuel & dual brake air pressure gauges
- Two-speed wipers with intermittent wipe
- HSA slow/fast engagement control with on/off switch
- ASR on/off switch, DPD manual regen switch
- **LH combination stalk:** wipers/wash, exhaust brake
- **RH combination stalk:** Indicators, light switch, headlamp dip switch, cruise control (AMT only)
- **Warning lamps:** Check engine, oil pressure, ABS, SRS, alternator charge, service brake, park brake on, seat belt, low air pressure, water-in-fuel, low fuel level, cab lock.
- **Indicator lamps:** HSA, warm up system, high beam, ASR, DPD status, 1st gear start,
- **AMT only:** AMT check light, AMT slow/fast, clutch engagement control, 1st gear selection, gear selection indicator display, cruise control, economy mode switch,
- **Multi display (AMT only):** shows service interval, instant and average fuel cons, DPD bar chart, voltmeter, hour meter, 40 – 120 kph adjustable speed warning, time/day/date

WEIGHTS (kgs)

Models	Model Code	RATINGS *		LOADING LIMITS (at ground)*		CHASSIS CAB TARE MASS **		
		GVM	GCM	FRONT	REAR	FRONT	REAR	TOTAL
FRR500 Tipper	FR0516	10,700	16,000	4000	7600	2370	2110	4480

* Vehicle ratings and front and rear mass limits are subject to regulatory requirements – Consult your dealer to select a specific vehicle to suit your requirements
 ** Chassis cab as supplied from the factory including 10 litres of fuel

DIMENSIONS (mm)

Models	WB	OAL	OAW	OAH	OAW	FOH	ROH	CW	RT	ORT	Kerb to Kerb (m)
FRR500 Tipper	3790	6255	2360	2520	2360	1170	1205	2200	1680	2152	12.0
* Unladen											

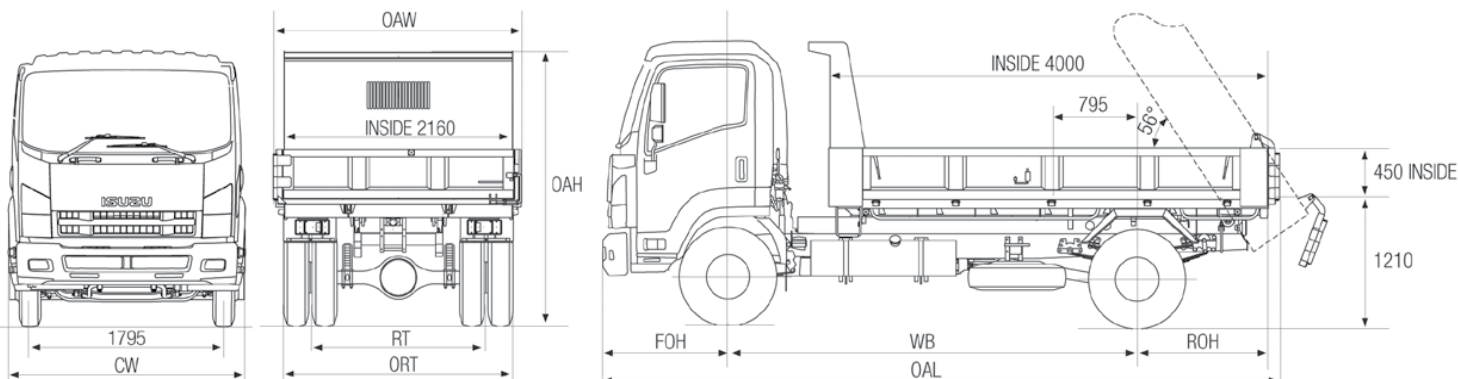

WARRANTY

Full vehicle warranty: 36 months or 150,000 kilometres whichever occurs first

All warranty is subject to terms and conditions as detailed in the Owner's Manual Service and Warranty Supplement

A policy of continuous improvement means that these specifications are subject to change without notice. Contact your Isuzu dealer or visit our website at Isuzu.co.nz to confirm specifications. Images of vehicles are representative only and may differ slightly from the actual vehicle