

Model	EXY460 MT	EXY460 AMT
GCM (kg)	55,000	55,000
GVM (kg)	24,000	24,000
Max Power (kW)	338	338
Max Torque (Nm)	2254	2254
Wheelbase (mm)	4300	4300
Cab	Low	Low
Suspension	Air	Air



## ENGINE

<b>Engine Model:</b>	6WG1 - TCC
<b>Type:</b>	6 cyl 24 valve, SOHC
<b>Displacement:</b>	15,681cc
<b>Compression Ratio:</b>	16.0:1
<b>Max Power (DIN Nett):</b>	338 kW (460 HP) @ 1800 RPM
<b>Max Torque (DIN Nett):</b>	2254 Nm (1663 lb.ft) @1,300
<b>Emission Control System:</b>	Euro V with SCR
<b>Fuel System:</b>	Electronically controlled Denso Direct Injection, high pressure common rail, 400 litre rectangular alloy fuel tank with lockable fuel cap, 75 litres Ad Blue
<b>Air Intake/Exhaust:</b>	Turbocharged, intercooled, vertical intake, horizontal outlet

Engine Performance Curve 6WG1 TCC

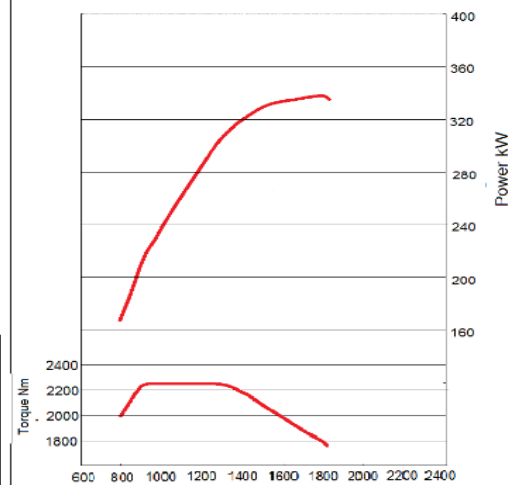

## TRANSMISSION

<b>Manual Ratios (:1)</b>	Eaton Road Ranger RTLO18918-B 18 speed 1 <sup>st</sup> 14.40, 2 <sup>nd</sup> 12.29, 3 <sup>rd</sup> 8.56, 4 <sup>th</sup> 7.30, 5 <sup>th</sup> 6.05, 6 <sup>th</sup> 5.15, 7 <sup>th</sup> 4.38, 8 <sup>th</sup> 3.74, 9 <sup>th</sup> 3.20, 10 <sup>th</sup> 2.73, 11 <sup>th</sup> 2.29, 12 <sup>th</sup> 1.92, 13 <sup>th</sup> 1.62, 14 <sup>th</sup> 1.38, 15 <sup>th</sup> 1.17, 16 <sup>th</sup> 1.00, 17 <sup>th</sup> 0.86, 18 <sup>th</sup> 0.73 Reverse: L/L 15.05 L/H 12.86, H/L 4.03 H/H 3.43
<b>PTO:</b>	Opening at bottom, 8 bolt SAE, 474Nm torque capacity
<b>Clutch:</b>	Spicer EP1552 ceramic 6-button twin plate 393mm diameter
<b>AMT Ratios (:1)</b>	Isuzu MJX16 1 <sup>st</sup> 14.01, 2 <sup>nd</sup> 11.34, 3 <sup>rd</sup> 9.93, 4 <sup>th</sup> 8.03, 5 <sup>th</sup> 6.84, 6 <sup>th</sup> 5.53, 7 <sup>th</sup> 4.58, 8 <sup>th</sup> 3.71, 9 <sup>th</sup> 3.05, 10 <sup>th</sup> 2.47, 11 <sup>th</sup> 2.16, 12 <sup>th</sup> 1.75, 13 <sup>th</sup> 1.49, 14 <sup>th</sup> 1.20, 15 <sup>th</sup> 1.00, 16 <sup>th</sup> 0.81, Rev 1: 12.58 Rev 2: 10.18
<b>PTO:</b>	Opening at left side of transmission
<b>Clutch:</b>	Air assisted 15.5" twin plate with clutch pedal shunting operations, not required for normal driving

## PERFORMANCE

**- 1<sup>st</sup> Gear Gradeability**  
**@GVM: M 44%/41.5% AMT**  
**Est Engine RPM @90km/h :**  
 Man 1440/1600 AMT

## AXLES

<b>Front Axle:</b>	Isuzu FO75
<b>Type:</b>	Elliot reverse I-beam
<b>Capacity:</b>	7500kgs
<b>Rear Axle:</b>	Isuzu RT210
<b>Type:</b>	Single speed tandem drive with inter-axle diff lock Integral oil pump
<b>Capacity:</b>	21000kgs
<b>Final Drive:</b>	Hypoid type, 420mm diameter ring gear
<b>Ratio:</b>	3.909:1

## CHASSIS

### Front Suspension

- Alloy steel tapered parabolic leaf springs
- Double acting shock absorbers with stabiliser bar

### Rear Suspension

- Isuzu 4-bag air suspension, stabilizer bars on both
- Hydraulic shock absorbers on both axles
- Remote hand control to adjust suspension height
- Auto return to factory-set ride height after 20km/hr
- Super Kick Drive facility for heavy duty starts

### Electrical

- 24 volt negative earth system
- 50 amp alternator
- Batteries - 2 x N120, 840 CCA @ 18°C

### Brakes

- Dual circuit full air, ABS.
- Drums 410mm diameter
- Front linings 160mm wide, Type 24 chambers
- Rear linings 220mm wide Type 24/30 chambers
- Twin cylinder air compressor 650cc
- Trailer brake hand control with limited travel

### Auxiliary retardation

- Isuzu X-Tard air controlled exhaust brake
- Provides up to 350HP (PS) retardation
- Isuzu Giga-Tard permanent magnet drive shaft retarder, up to 65kg/m silent braking

### Chassis Frame

- Rolled steel channel, cold riveted ladder frame  
Rail dimensions 285 x 85 x 7 mm
- HT540 weldable steel
- Frame width 850mm, 950mm at engine/trans
- Inner frame reinforcement at suspension mounts

### Wheels and Tyres

- 8.25" x 22.5" 165mm offset Alcoa alloy wheels
- 10 stud, 22mm hole size, 335mm PCD
- Tyres 275/70R22.5 148/145 front and rear

### Steering

- Power assisted recirculating ball with integral power assistance, gear Ratio 20.2:1

## CAB AND INTERIOR

### CAB EXTERIOR

- All steel construction, standard roof, high tensile steel on cab under-frame with side impact beam reinforcement
- Cab strength equivalent to ECE-R29 standard
- Power cab tilt to 48° with manual hydraulic back-up
- 4 point electronically controlled air bag cab suspension
- Enclosed non-slip cab entry steps with RH step light
- Door mounted 22" heated power main and convex mirrors
- LH side kerb and front under-view mirrors
- External-access equipment locker on left side of cab
- Steel front bumper integral head lamps, fog lamps and indicator
- Halogen multi-reflector headlamps,
- Roof-mounted outline marker lamps
- Reverse alarm buzzer standard

### CAB INTERIOR

- Driver's seat - ISRI 6860 air suspended, pneumatic lumbar support, height, rake, auto weight adjustment seat for occupant mass up to 150kg
- SRS including air bag on driver's seat
- Door and pillar entry assist grips both sides

### CAB INTERIOR (continued)

- Two overhead storage lockers with CB compatible slot
- Height/reach adjustable steering column, soft-feel urethane steering wheel,
- Electric windows
- Central locking with keyless entry and engine immobiliser
- Air conditioning with redirect to sleeper
- Two 12V 100W accessory power outlets and 24V cigarette lighter
- Door mounted storage pockets, LH and RH glove boxes
- Centre console with storage locker, fold-over storage tray and two storage ports/cup holders
- Carbon fibre style dash facia
- MultiMedia radio/CD/DVD/MP3/WMA Player with 6.2" Touch Screen, Bluetooth, voice dialling, text to speech, SD and USB inputs, on-board recordable memory, optional external cameras with up to 4-way screen, GPS navigation and many other options

### Instruments and Controls

- Speedometer with digital odometer and trip meters
- Engine coolant temperature, fuel and AdBlue gauges, dual brake air pressure gauges
- Two-speed wipers with variable intermittent wipe function
- Differential lock switch with "Engaged" light
- Idle speed adjustment switch
- Giga-Tard progressive engagement switch
- LH combination stalk: windscreen wipers/wash control, hazard lamps, X-Tard exhaust brake, Giga-Tard on/off
- RH combination stalk: Indicators, lights & fog lamp switch, headlamp dip switch, cruise control set/resume/cancel
- Multi Display provides : Clock, calendar, fuel consumption data including total economy and fuel consumption, trip distance, trip economy and fuel consumption (when moving), Idle consumption (when stationary), battery voltage.
- Multi info display warnings include: Engine overheat, low coolant level, low oil pressure, low fuel level.

## WEIGHTS (kgs)

Model Code	MODELS	RATINGS *		LOADING LIMITS (at ground)*		CHASSIS CAB TARE MASS **		
		GVM	GCM	FRONT ***	REAR	FRONT	REAR	TOTAL
EX0215	EXY460 MT	24 000	55000	6000	15000	4760	3455	8215
EX0115	EXY460 AMT	24 000	55000	6000	15000	4730	3465	8195

\* Vehicle ratings and front and rear mass limits are subject to regulatory requirements – Consult your dealer to select a specific vehicle to suit your requirements  
 \*\* Chassis cab as supplied from the factory including 10 litres of fuel

## DIMENSIONS (mm)

Models	WB	OAL	OAH *	FOH	ROH	CA	RI	CE	RT	ORT	FW	RFH *	AF	CW	Kerb to Kerb (m)
EXY460 MT	4300	7220	3034	1400	1520	3500	1310	5011	1780	2475	850	963	656	2490	15.0
EXY460 AMT	4300	7220	3034	1400	1520	3500	1310	5011	1780	2475	850	963	656	2490	15.0

\* Unladen condition

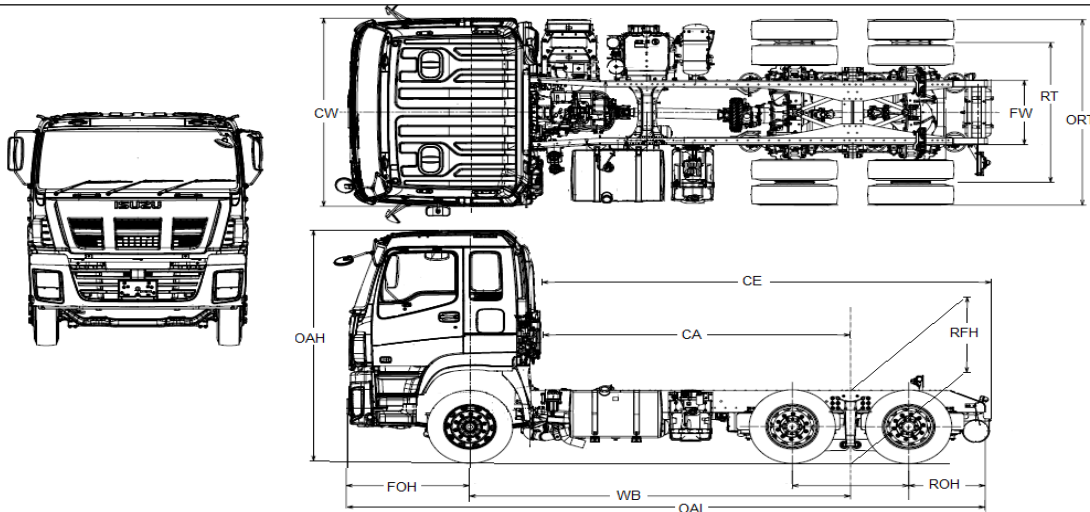

## WARRANTY

**Full vehicle warranty:** 36 months or 250,000 kilometres whichever occurs first

All warranty is subject to terms and conditions as detailed in the Owner's Manual Service and Warranty Supplement

A policy of continuous improvement means that these specifications are subject to change without notice. Contact your Isuzu dealer or visit our website at [Isuzu.co.nz](http://Isuzu.co.nz) to confirm specifications. Images of vehicles are representative only and may differ slightly from the actual vehicle