

Model	CYZ530
GCM (kg)	58,000
GVM (kg)	24,000
Max Power (kW)	390
Max Torque (Nm)	2254
Wheelbase (mm)	4300
Cab	Low
Suspension	Steel



ENGINE

Engine Model:	6WG1 - TCS
Type:	6 cyl 24 valve, SOHC
Displacement:	15,681cc
Compression Ratio:	16.0:1
Max Power (DIN Nett):	390 kW (530 HP) @ 1800 RPM
Max Torque (DIN Nett):	2254 Nm (1663 lb.ft) @ 1,300
Emission Control System:	Euro V with SCR
Fuel System:	Electronically controlled Denso Direct Injection, high pressure common rail, 400 litre rectangular alloy fuel tank with lockable fuel cap, 75 litres Ad Blue
Air Intake/Exhaust:	Turbo charged, intercooled, vertical intake, horizontal outlet

Engine Performance Curve 6WG1 TCS

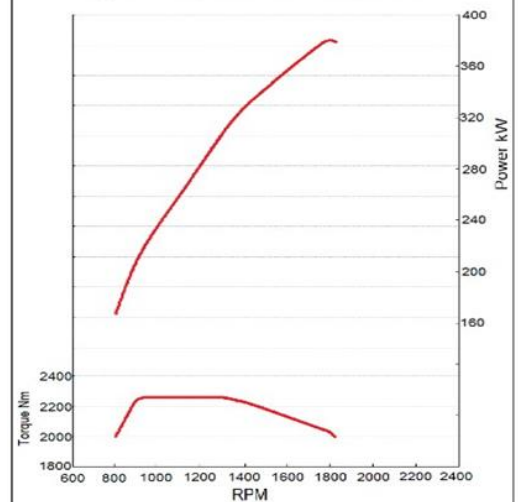

PERFORMANCE

- 1st Gear Gradeability @GCM: 43% - Est Engine RPM @90km/h : 1456

TRANSMISSION

Manual Ratios (:1)	Eaton Road Ranger RTLO18918-B 18 speed 1 st 14.40, 2 nd 12.29, 3 rd 8.56, 4 th 7.30, 5 th 6.05, 6 th 5.15 7 th 4.38, 8 th 3.74, 9 th 3.20, 10 th 2.73, 11 th 2.29, 12 th 1.92 13 th 1.62, 14 th 1.38. 15 th 1.17, 16 th 1.00, 17 th 0.86, 18 th 0.73
PTO:	Reverse: L/L 15.05 L/H 12.86, H/L 4.03 H/H 3.43 Opening at bottom, 8 bolt SAE, 474Nm torque capacity
Clutch:	Spicer EP1552 ceramic 6-button twin plate 393mm diameter

AXLES

Front Axle:	Isuzu FO75
Type:	Elliot reverse I-beam
Capacity:	7500kgs
Rear Axle:	Isuzu RT260
Type:	Single speed tandem drive with inter-axle diff lock Integral oil pump
Capacity:	26000kgs
Final Drive:	Hypoid type, 445mm diameter ring gear
Ratio:	4.33:1

CHASSIS

Front Suspension

- Alloy steel tapered parabolic leaf springs
- Double acting shock absorbers with stabiliser bar

Rear Suspension

- Isuzu 6-rod and trunnion axle locating system
- Alloy steel parabolic tapered leaf springs

Electrical

- 24 volt negative earth system
- 60-amp alternator
- Batteries - 2 x N120, 660 CCA @ 18°C

Steering

- Power assisted recirculating ball with integral power assistance. Gear Ratio 20.2:1

Brakes

- Dual circuit full air, ABS.
- Drums 410mm diameter
- Front linings 160mm wide, Type 24 chambers
- Rear linings 220mm wide Type 24/30 chambers
- Twin cylinder air compressor 650cc
- Trailer brake hand control with limited travel

Auxiliary retardation

- Isuzu X-Tard air controlled exhaust brake
- Provides up to 350HP (PS) retardation
- Isuzu Giga-Tard permanent magnet drive shaft retarder, up to 65kg/m silent braking

Chassis Frame

- Rolled steel channel, cold riveted ladder frame
- Rail dimensions 318 x 90 x 7 mm
- HT540 weldable steel
- Rail width 950mm at engine/transmission
850mm rearwards of transmission

Wheels and Tyres

- 8.25" x 22.5" 165mm offset Alcoa alloy wheels
- 10 stud, 22mm hole size, 335mm PCD
- Tyres 11.00R22.5 148/145 Rated front and rear

CAB AND INTERIOR

CAB EXTERIOR

- All steel construction, standard roof, high tensile steel on cab under-frame with side impact beam reinforcement
- Cab strength equivalent to ECE-R29 standard
- Power cab tilt to 48° with manual hydraulic back-up
- 4 point electronically controlled air bag cab suspension
- Enclosed non-slip cab entry steps with RH step light
- Door mounted 22" heated power main and convex mirrors
- LH side kerb and front under-view mirrors
- External-access equipment locker on left side of cab
- Steel front bumper integral head lamps, fog lamps and indicator
- Halogen multi-reflector headlamps,
- Roof-mounted outline marker lamps
- Reverse alarm buzzer standard

CAB INTERIOR

- Driver's seat - ISRI 6860 air suspended, pneumatic lumbar support, height, rake, auto weight adjustment seat for occupant mass up to 150kg
- SRS including air bag on driver's seat
- Door and pillar entry assist grips both sides

CAB INTERIOR (continued)

- Two overhead storage lockers with CB compatible slot
- Height/reach adjustable steering column, soft-feel urethane steering wheel,
- Electric windows
- Central locking with keyless entry and engine immobiliser
- Air conditioning with redirect to sleeper
- Two 12V 100W accessory power outlets and 24V cigarette lighter
- Door mounted storage pockets, LH and RH glove boxes
- Centre console with storage locker, fold-over storage tray and two storage ports/cup holders
- Carbon fibre style dash facia
- MultiMedia radio/CD/DVD/MP3/WMA Player with 6.2" Touch Screen, Bluetooth, voice dialling, text to speech, SD and USB inputs, on-board recordable memory, optional external cameras with up to 4-way screen, GPS navigation and many other options

Instruments and Controls

- Speedometer with digital odometer and trip meters
- Engine coolant temperature, fuel and AdBlue gauges, dual brake air pressure gauges
- Two-speed wipers with variable intermittent wipe function
- Differential lock switch with "Engaged" light
- Idle speed adjustment switch
- Giga-Tard progressive engagement switch
- LH combination stalk: windscreen wipers/wash control, hazard lamps, X-Tard exhaust brake, Giga-Tard on/off
- RH combination stalk: Indicators, lights & fog lamp switch, headlamp dip switch, cruise control set/resume/cancel
- Multi Display provides : Clock, calendar, fuel consumption data including total economy and fuel consumption, trip distance, trip economy and fuel consumption (when moving), Idle consumption (when stationary), battery voltage.
- Multi info display warnings include: Engine overheat, low coolant level, low oil pressure, low fuel level.

WEIGHTS (kgs)

Model Code	MODELS	RATINGS *		LOADING LIMITS (at ground)*		CHASSIS CAB TARE MASS **		
		GVM	GCM	FRONT ***	REAR	FRONT	REAR	TOTAL
CZ0415	CYZ530	24 000	58 000	6000	15000	4520	3620	8140

* Vehicle ratings and front and rear mass limits are subject to regulatory requirements – Consult your dealer to select a specific vehicle to suit your requirements
 ** Chassis cab as supplied from the factory including 10 litres of fuel

DIMENSIONS (mm)

Models	WB	OAL	OAH *	FOH	ROH	CA	RI	CE	RT	ORT	FW	RFH *	CW	Kerb to Kerb (m)
CYZ530	4300	7650	3130	1400	1950	3849	1310	5450	1870	2480	850	1135	2490	15.0

* Unladen condition

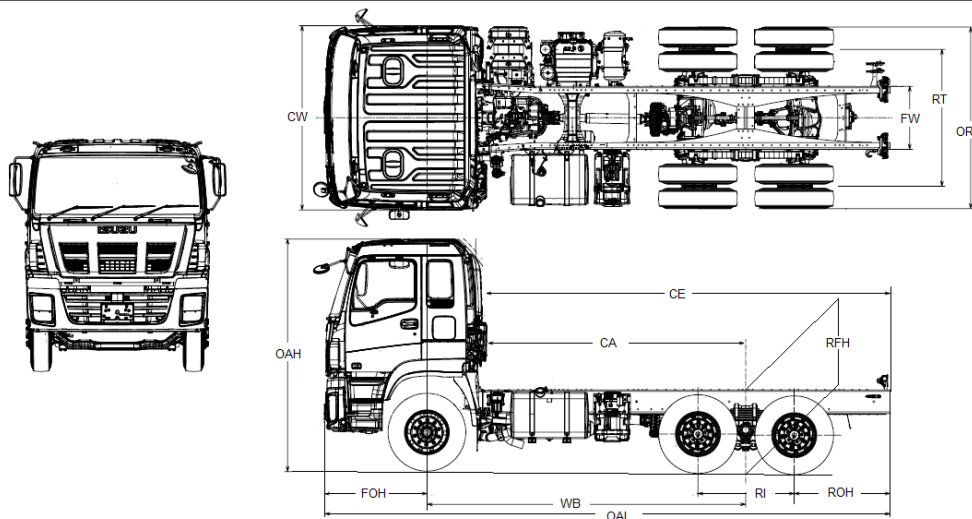

WARRANTY

Full vehicle warranty: 36 months or 250,000 kilometres whichever occurs first

All warranty is subject to terms and conditions as detailed in the Owner's Manual Service and Warranty Supplement

A policy of continuous improvement means that these specifications are subject to change without notice. Contact your Isuzu dealer or visit our website at Isuzu.co.nz to confirm specifications. Images of vehicles are representative only and may differ slightly from the actual vehicle