

Model	CYJ400 AMT
GCM (kg)	55,000
GVM (kg)	29,000
Max Power (kW)	294
Max Torque (Nm)	1863
Wheelbase (mm)	5980
Cab	Low
Suspension	Air



ENGINE

Engine Model:	6WG1 - TCR
Type:	6 cyl 24 valve, SOHC
Displacement:	15,681cc
Compression Ratio:	16.0:1
Max Power (DIN Nett):	294 kW (400 HP) @ 1800 RPM
Max Torque (DIN Nett):	1863Nm (1374 lbs/ft) @ 1300
Emission Control System:	Euro V with Diesel Oxidation Catalyst
Fuel System:	Electronically controlled Denso Direct Injection, high pressure common rail, 400 litre rectangular alloy fuel tank with lockable fuel cap.
Air Intake/Exhaust:	Turbocharged, intercooled, vertical intake, horizontal outlet

ISUZU 6WG1-TCR

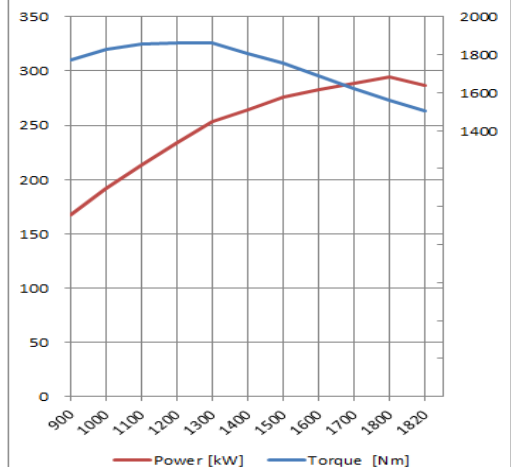

PERFORMANCE

- 1st Gear Gradeability @GVM: 45.7%

- Est Engine RPM @90km/h : 1595

TRANSMISSION

Make/Model	Isuzu MJX16 Automated Manual Transmission
Ratios (:1)	1 st 14.01, 2 nd 11.34, 3 rd 9.93, 4 th 8.03, 5 th 6.84, 6 th 5.53, 7 th 4.58, 8 th 3.71, 9 th 3.05, 10 th 2.47, 11 th 2.16, 12 th 1.75, 13 th 1.49, 14 th 1.20, 15 th 1.00, 16 th 0.81, Rev 1: 12.58 Rev 2: 10.18
PTO:	Opening at left side of transmission
Clutch:	Air assisted 15.5" twin plate with clutch pedal for low-speed yard shunting operations, not required for normal driving

AXLES

Front Axles:	Isuzu FO66 x 2
Type:	Elliot reverse I-beam
Capacity:	13200 kgs
Rear Axle:	Isuzu RT210
Type:	Single speed tandem drive with inter-axle diff lock Integral oil pump
Capacity:	21000kgs
Final Drive:	Hypoid type, 445mm diameter ring gear
Ratio:	3.909:1

CHASSIS

Front Suspension

- Alloy steel tapered parabolic leaf springs
- Double acting shock absorbers with stabiliser bar on Front axle

Rear Suspension

- Isuzu 4-bag air suspension, stabilizer bars on both
- Hydraulic shock absorbers on both axles
- Remote hand control to adjust suspension height
- Auto return to factory-set ride height after 20km/hr
- Super Kick Drive facility for heavy duty starts

Electrical

- 24 volt negative earth system
- 50 amp alternator
- Batteries - 2 x N120, 610 CCA @ 18°C

Brakes

- Dual circuit full air, ABS.
- Drums 410mm diameter
- Front linings 160mm wide, Type 24 chambers
- Rear linings 220mm wide Type 24/30 chambers
- Twin cylinder air compressor 650cc
- Trailer brake hand control with limited travel

Auxiliary retardation

- Isuzu X-Tard air controlled exhaust brake
- Provides up to 350HP (PS) retardation
- Isuzu Giga-Tard permanent magnet drive shaft retarder provides up to 65kg/m silent retardation

Chassis Frame

- Rolled steel channel, cold riveted ladder frame
- Rail dimensions 285 x 90 x 7 mm
- HT540 weldable steel
- Frame width 850mm, 950mm at engine/trans
- Inner frame reinforcement at suspension mounts

Wheels and Tyres

- 8.25" x 22.5" 165mm offset steel wheels
- 10 stud, 22mm hole size, 335mm PCD
- Tyres 275/70R22.5 148/145 front and rear

Steering

- Power assisted recirculating ball with integral power assistance
- Gear Ratio 20.2:1

CAB AND INTERIOR

CAB EXTERIOR

- All steel construction, standard roof, high tensile steel on cab under-frame with side impact beam reinforcement
- Cab strength equivalent to ECE-R29 standard
- Power cab tilt to 48° with manual hydraulic back-up
- 4 point electronically controlled air bag cab suspension
- Enclosed non-slip cab entry steps with RH step light
- Door mounted 22" heated power main & convex mirrors
- LH side kerb and front under-view mirrors
- External-access equipment locker on left side of cab
- Steel front bumper integral head lamps, fog lamps and indicator
- Halogen multi-reflector headlamps,
- Roof-mounted outline marker lamps
- Reverse alarm buzzer standard

CAB INTERIOR

- Driver's seat - ISRI 6860 air suspended, pneumatic lumbar support, height, rake, auto weight adjustment seat for occupant mass up to 150kg
- Front passenger adjustable bucket seat
- 3-point ELR seatbelts on both seat positions, driver's seat fitted with pre-tensioner integral to the seat
- SRS including air bag on driver's seat

CAB INTERIOR (continued)

- Two overhead storage lockers
- Height/reach adjustable steering column, soft-feel urethane steering wheel
- Electric windows
- Fully integrated air conditioning
- Central locking with keyless entry and engine immobiliser
- 24V accessory power outlet and cigarette lighter
- Door mounted storage pockets, LH and RH glove boxes
- Centre console with storage locker, fold-over storage tray and two storage ports/cup holders
- MultiMedia radio/CD/DVD/MP3/WMA Player With 6.2" Touch Screen, Bluetooth, voice dialing, text to speech, SD and USB inputs, on-board recordable memory, optional external cameras with up to 4-way screen, GPS navigation and many other options *
- Full all-round curtains with partition curtain for sleeper area
- Fluorescent interior lamp

Instruments and Controls

- Speedometer with digital odometer and two trip meters and electronic tachometer
- Engine coolant temperature, fuel & brake air gauges
- Two-speed wipers with intermittent wipe
- Idle speed adjustment switch
- combination stalks: Indicators, lights & fog lamp switch, headlamp dip switch, cruise control set/resume/cancel
- Warning lamps: Check engine, oil pressure, ABS fault, SRS, alternator charge, service brake, park brake on, seat belt, low air pressure (with buzzer, water-in-fuel, low fuel level, seat belt reminder)
- Indicator lamps for: Trailer non-ABS, park brake on, turn signal, high beam, trailer hand control on, cruise control main/set, cab lock
- Multi Display provides : Clock, calendar, fuel consumption data including total economy and fuel consumption, trip distance, trip economy and fuel consumption (when moving), Idle consumption (when stationary), battery voltage.
- Multi info display warnings include: Engine overheat, low coolant level, low oil pressure, low fuel level.

WEIGHTS (kgs)

Model Code	MODELS	RATINGS *		LOADING LIMITS (at ground)*		CHASSIS CAB TARE MASS **		
		GVM	GCM	FRONT ***	REAR	FRONT	REAR	TOTAL
CJ0115	CYJ400 AMT	29 000	55 000	10800	15000	6260	2850	9110

* Vehicle ratings and front and rear mass limits are subject to regulatory requirements – Consult your dealer to select a specific vehicle to suit your requirements
 ** Chassis cab as supplied from the factory including 10 litres of fuel

DIMENSIONS (mm)

Models	WB	OAL	OAH *	FOH	ROH	CA	FI	RI	CE	RT	ORT	FW	RFH *	AF	CW	Kerb to Kerb (m)
CYJ400 AMT	5980	9610	3078	1400	2325	5190	1850	1310	7421	1850	2480	850	957	789	2940	21.4

* Unladen condition

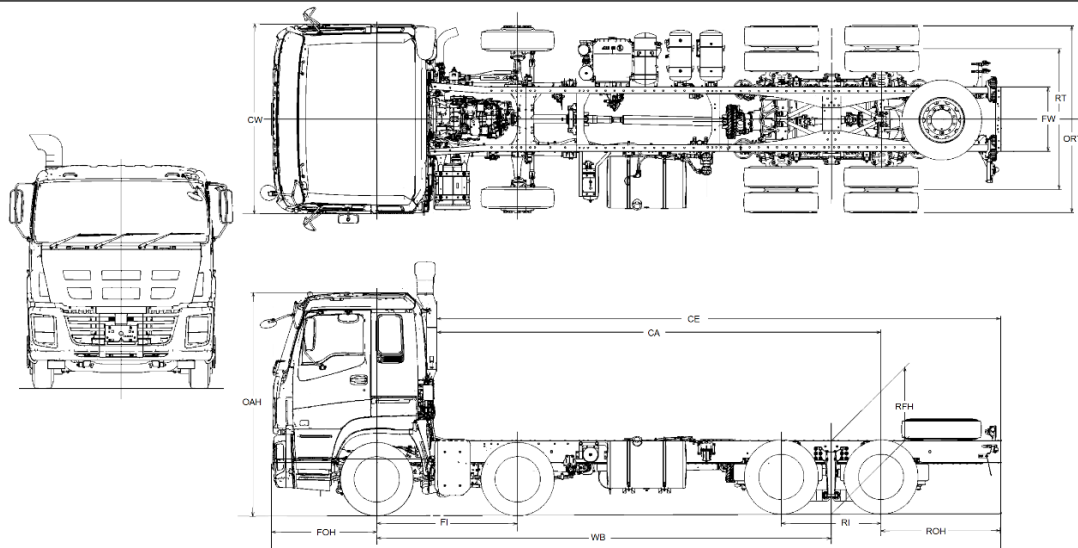

WARRANTY

Full vehicle warranty: 36 months or 250,000 kilometres whichever occurs first

All warranty is subject to terms and conditions as detailed in the Owner's Manual Service and Warranty Supplement

A policy of continuous improvement means that these specifications are subject to change without notice. Contact your Isuzu dealer or visit our website at Isuzu.co.nz to confirm specifications. Images of vehicles are representative only and may differ slightly from the actual vehicle